

Model 418

**Color Reflection
Densitometer**

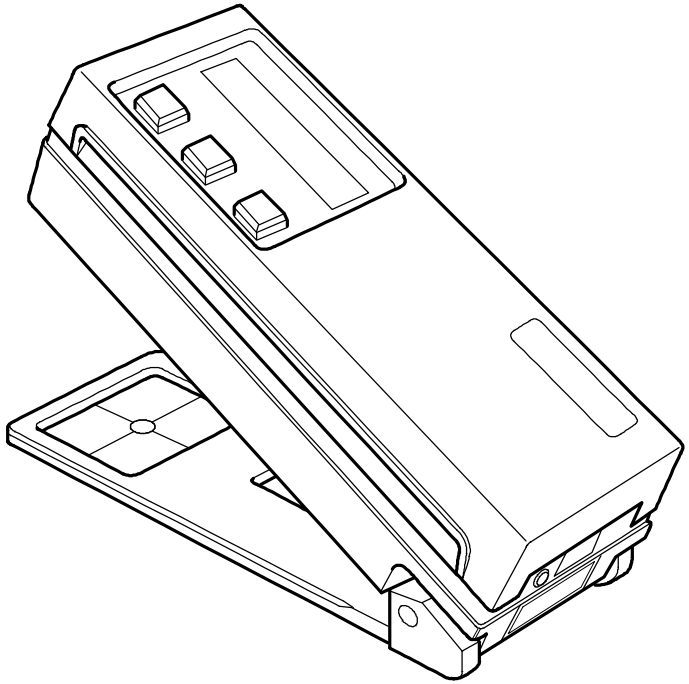

Operation Manual

X-Rite 



Dear Customer:

Congratulations! We at X-Rite, Incorporated are proud to present you with the X-Rite 418 Color Reflection Densitometer. This instrument represents the very latest in microcontrollers, integrated circuits, optics, and display technology. Your X-Rite 418 is a rugged, reliable, finely engineered instrument whose performance is unsurpassed.

To fully appreciate and protect your investment, we suggest that you take the necessary time to read and fully understand this manual. As always, X-Rite stands behind your 418 with a full one year limited warranty and a dedicated service organization. If the need arises, please don't hesitate to call us.

Thank you for your trust and confidence.

X-Rite, Incorporated

CE DECLARATION

Manufacturer's Name: X-Rite, Incorporated
Manufacturer's Address: 3100 44th Street, S.W.
Grandville, Michigan 49418
U.S.A.

Model Name: Densitometer
Model No.: 418

Directive(s) Conformance: EMC 89/336/EEC LVD 73/23/EEC

NOTE: The device complies to the product specifications for the Low Voltage Directive when furnished with the 230VAC AC Adapter (X-Rite P/N SE30-62), and to UL Standards when furnished with the 115VAC AC Adapter (X-Rite P/N SE30-61).

FEDERAL COMMUNICATIONS COMMISSION NOTICE

FCC Statement

This equipment has been tested and found to comply with the limits for a Class A digital device, pursuant to Part 15 of the FCC Rules. These limits are designed to provide reasonable protection against harmful interference when the equipment is operated in a commercial environment. This equipment generates, uses, and can radiate radio frequency energy and, if not installed and used in accordance with the instruction manual, may cause harmful interference to radio communications. Operation of this equipment in a residential area is likely to cause harmful interference in which case the user will be required to correct the interference at his own expense.

Canada

This Class A digital apparatus meets all requirements of the Canadian Interference-Causing Equipment Regulations.

Cet appareil numérique de la classe A respecte toutes les exigences du Règlement sur le matériel brouilleur du Canada.

The Manufacturer:	X-Rite, Incorporated
Der Hersteller:	3100 44th Street, S.W.
El fabricante:	Grandville, Michigan 49418
Le fabricant:	
Il fabbricante:	

Declares that:	Densitometer
gibt bekannt:	418
advierte que:	
avertit que:	
avverte che:	



is not intended to be connected to a public telecommunications network.

an ein öffentliches Telekommunikations-Netzwerk nicht angeschlossen werden soll.

no debe ser conectado a redes de telecomunicaciones públicas.

ne doit pas être relié à un réseau de télécommunications publique.

non deve essere connesso a reti di telecomunicazioni pubblici.

NOTE: Shielded interface cables must be used in order to maintain compliance with the desired FCC and European emission requirements.

CAUTION: Operational hazard exists if AC adaptor other than X-Rite SE30-61 (115V) or SE30-62 (230V) is used.

VORSICHT: Es besteht Betriebsgefahr bei der Verwendung von einem Adapter außer X-Rite SE30-61 (115 U) oder SE30-62 (230 U).

AVISO: No use otro adaptador C.A. que no sea la pieza X-Rite SE30-61 (115V) o SE30-62 (230V), por el riesgo de mal funcionamiento del equipo.

ATTENTION: Ne pas utiliser d'adaptateur autre que SE30-61 (115V) ou SE30-62 (230V) de X-Rite au risque de mauvais fonctionnement de l'appareil.

AVVISO: Non usare un altro adattatore C.A. che non è del pezzo X-Rite SE30-61 (115V) o SE30-62 (230V), per il rischio di malfunzionamento dell'apparecchio.

WARNING: This instrument is not for use in explosive environment.

WARNUNG: Das Gerät soll in einer explosiven Umgebung NICHT verwendet werden.

ADVERTENCIA: NO use este aparato en los ambientes explosivos.

ATTENTION: Cet instrument NE DOIT PAS être utilisé dans un environnement explosif.

AVVERTIMENTO: NON usare questo apparecchio in ambienti esplosivi.

USE ONLY: AA NiCad batteries that are 600/700mAh rated, six required. Other types may burst causing personal injury.

AUFGEPASST: Verwenden Sie nur AA Nicad Akkus von 600/700mAh (Milliampere/Stunde) Nennstrom (6 Stück erforderlich). Mit anderen Akkus läuft die Gefahr von Explosion und Verletzung.

ATENCION: Use solamente las pilas de AA NiCad (se requiere seis) con condiciones de funcionamiento normales 600/700mAh (horas miliamperios). Es posible que los otros tipos puedan estallar y causar daños corporales.

ATTENTION: Utiliser seulement les batteries NiCad à courant nominal de 600mAh (milliampère/heure) (6 pièces nécessaire). Il y a danger d'explosion et de blessures avec les autres types.

ATTENZIONE: Usare solamente gli accumulatori al AA NiCad (si richiede sei) con le condizioni di funzionamento normali 600/700mAh (ore milliamperi). E possibile che altri tipi possano scoppiare e causare danno personale.

Contents

1 Overview and Setup	
Features	1-1
Packaging and Parts	1-3
Instrument Vocabulary.....	1-4
Unlocking/Locking the Shoe	1-5
Batteries and Power	1-6
Adjusting the Display Angle	1-8
I/O Port Setup.....	1-9
2 Calibration	
Response Settings	2-1
Overview of Calibration Procedures	2-3
Long Calibration.....	2-4
Color Correlation (CC) Calibration.....	2-7
Quick-Cal™	2-10
3 Electronic Function Selection	
EFS Measurement	3-2
4 Density Functions	
Selecting Density Function	4-2
Selecting Density Mode	4-3
Selecting Color Measurement Method	4-5
Density Measurement.....	4-6
Density Difference Measurement	4-8
5 Dot Functions	
Selecting Dot Area or Dot Gain	5-2
Selecting Measurement Method.....	5-3
Dot Area Function.....	5-4
Dot Gain Function.....	5-6
6 Trap Functions	
Trap Formulas	6-1
Selecting Trap Function.....	6-3
Trap Measurement	6-5
Trap Difference Measurement.....	6-8
Trap DMAX Entry	6-10

7	Print Contrast Functions	
	Selecting Print Contrast Function	7-2
	Selecting Print Contrast Mode	7-3
	Selecting Color Measurement Method	7-5
	Print Contrast Measurement.....	7-7
	Print Contrast Difference Measurement.....	7-9
8	Hue Error & Grayness Functions	
	Formulas.....	8-1
	Selecting Hue Error/Grayness Function	8-2
	Selecting Hue Error/Grayness Mode	8-3
	Hue Error/Grayness Measurement	8-5
9	Technical Information	
	Serial Interface Information	9-1
	Instrument Specifications	9-4
	Accessories	9-6
	General Cleaning.....	9-7
	Optics Maintenance.....	9-7
	Target Window Replacement.....	9-8
	Lamp Replacement	9-9
10	Appendices and Index	
	Display Messages.....	10-1
	Proprietary Notice.....	10-3
	Limited Warranty	10-4
	Index.....	10-5

Copyright 1987, 1997 by
X-Rite, Incorporated
“ALL RIGHTS RESERVED”

X-Rite is a registered trademark and Quick Cal™, Q Cal™, Electronic Function Selection™, Computerized Color Response™, and CCR™, are trademarks of X-Rite, Incorporated. All other logos, brand names, and product names are the properties of their respective holders.

Features	1-1
Packaging and Parts.....	1-3
Instrument Vocabulary	1-4
Unlocking/Locking the Shoe.....	1-5
Batteries and Power.....	1-6
Adjusting the Display Angle.....	1-8
I/O Port Setup.....	1-9

The X-Rite 418 Color Reflection Densitometer is designed to meet the quality control needs of today's pressroom and graphic arts technicians. This completely portable instrument features different measurement modes for quickly measuring ink density, density difference, dot area, dot gain, trap, print contrast, hue error, and grayness. Measurements are taken with simple hand-held operation, and measurement data is clearly read on the interactive display. The three control buttons make measurement mode selection easy.

FEATURES

The X-Rite 418 features several state-of-the-art technologies that place the instrument a step above competitive instruments in terms of accuracy, speed, and simplicity:

Computerized Color Response™ (CCR)

The versatile 418 accommodates multiple status responses. Model 418G can take measurements using ANSI-Status T response, which is compatible with the GCA T-reference (T-Ref) standard. You can also select the traditional X-Rite graphic arts response, Status G. Model 418E features European Status E and Status I (displayed as N) responses.

QuickCal™ One-Step Calibration

The 418's Quick-Cal feature makes calibration fast and easy. You simply select the "Q-Cal" mode on the instrument, then measure the white patch on the supplied calibration target card. You can also get complete agreement with other densitometers using the three-color response calibration.

Automatic On/Shut-Off

To increase battery life, the 418 automatically turns itself off if it has not been used within 45 seconds; and it automatically turns back whenever a key is pressed or measurement taken. Tests have shown that over 4,500 readings can be taken on one charge of new batteries.

Nonvolatile Memory

A lithium battery stores calibration data and measured values when the densitometer's primary rechargeable batteries are depleted or removed.

Automatic Color Selection

Equipped with Auto Color Select, the 418 eliminates manual rotation of a filter wheel and related erroneous measurements. All colors are measured simultaneously, then the correct reading is displayed in less than one second.

Additional Features

- Large LCD display clearly identifies measurement data and mode function. No need for numeric codes to identify this information.
- Three large buttons place all function controls at operator's fingertips.
- Small 1.7mm aperture (GS or ES model) for reading reduced-size color bar patches.
- AC adapter is provided to allow readings while batteries are being recharged.
- Replaceable optics allow you to switch between "G" and "E" response.
- Two-way RS-232 interface operates at 1200 baud, or one of several other baud rates.

PACKAGING AND PARTS

After removing the instrument from the shipping carton, inspect for possible damage. If any damage is noted, contact the transportation company immediately. Do nothing more until the carrier's agent has inspected the damage.

If damage is not evident, check to ensure that all items are included (refer to the parts list below).

Your Package Should Include...

- 1 418 Color Reflection Densitometer
- 1 Carrying Case
- 1 Operation Manual
- 1 Color Reflection Calibration Reference;
either 418-62 for Model 418 *or* 418/LP-62 for Model 418/LP
- 1 Warranty Registration Card
- 1 P/N SE30-61 Battery Charger, 115V
or P/N SE30-62 Battery Charger, 230V
- 1 P/N SD01-41 Certificate of Calibration

Along with this Operation Manual, several important notices are included. You should read each of these notices before using the instrument.

Return Packaging

Your X-Rite 418 was packaged in a carton specially designed to prevent damage. If re-shipment is necessary, the instrument should be re-packaged in the original carton. If the original carton is not available, a new one can be obtained from X-Rite.

INSTRUMENT VOCABULARY

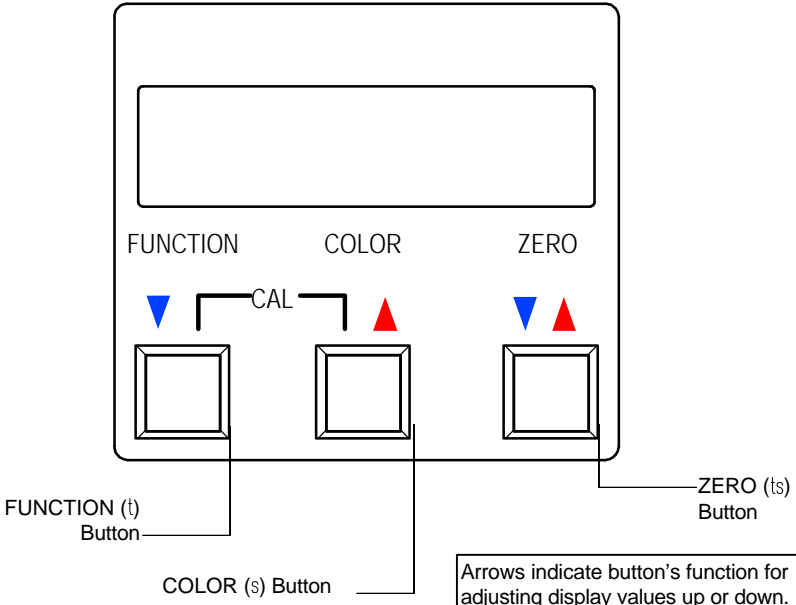
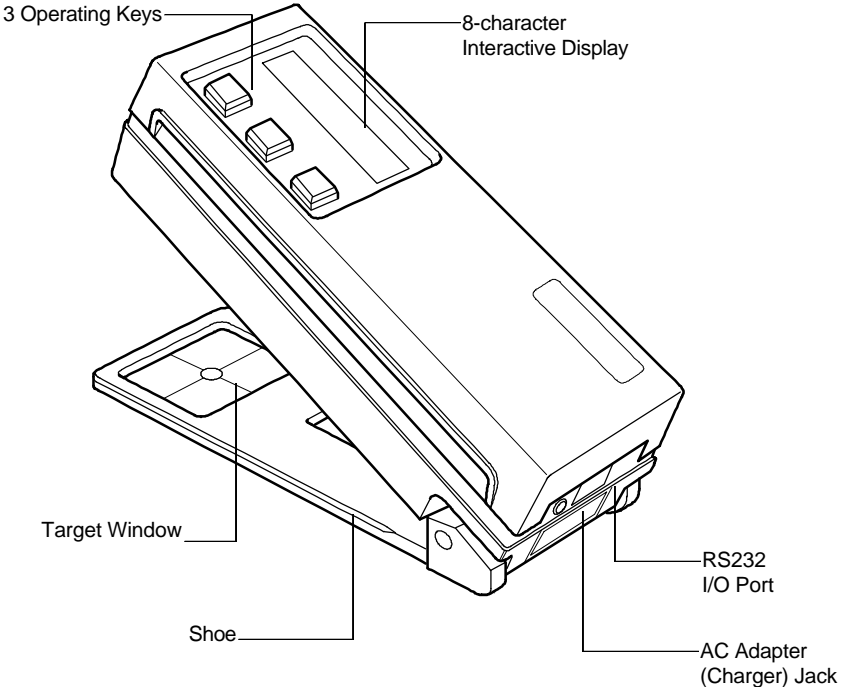

UNLOCKING/LOCKING THE SHOE

To take measurements with the instrument, you must unlock the Shoe (see Instrument Vocabulary drawing on previous page). When the instrument is not in use, the Shoe should be re-locked to protect the instrument optics.

A sliding button on the bottom of the instrument locks the Shoe closed.

To unlock, hold Shoe against the unit and slide the lock button back until the button latch clears the Shoe tab. Carefully release the Shoe to open. (Figure 1-1)

To lock, hold the Shoe against the unit and slide the lock button forward until the button latch captures the Shoe tab. (Figure 1-2)

Figure 1-1

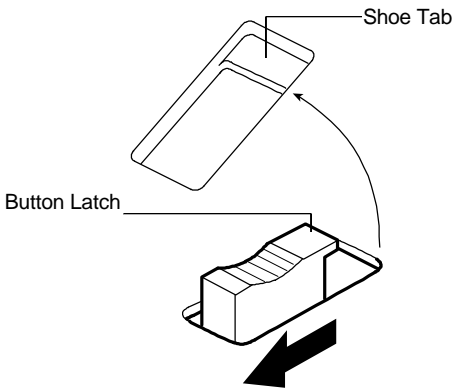
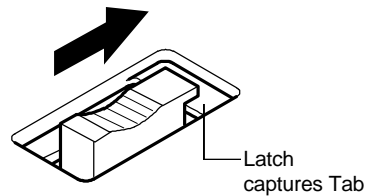

Figure 1-2



BATTERIES AND POWER

Your 418 instrument's batteries should be charged before use. It can be operated while the batteries are being charged.

Before you begin charging, you must remove the battery isolation insert protruding from the battery cover. (Figure 1-3)

Figure 1-3

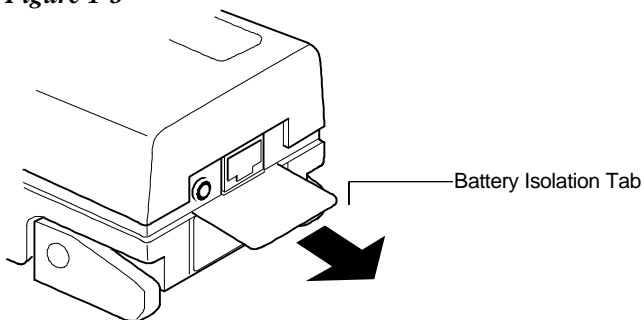

NOTE: Make sure the voltage indicated on the AC adapter complies with the AC line voltage in your area. If it does not, contact your X-Rite dealer.

To charge the battery:

1. Plug the AC Adapter Line Cord into the AC Adapter Jack on back of instrument. (Figure 1-4)
2. Plug AC Adapter into AC wall outlet. You can use the instrument while it recharges. The instrument will be fully charged in approximately 14 hours.

Figure 1-4

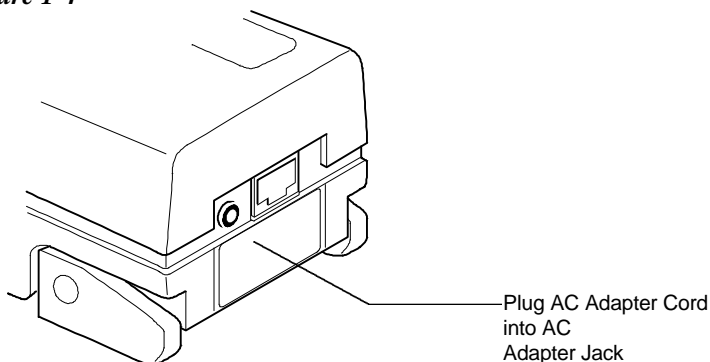

NOTE: If your unit has not been used for several weeks recharge for approximately 24 hours.

NOTE: When storing the unit for a long period of time, the batteries should be removed.

Applying Power

The instrument remains “powered down” until a measurement is taken. When a measurement is taken, or when any key is pressed, the instrument automatically turns on.

If no measurements are taken or keys pressed for 45 seconds, the instrument automatically turns off again to conserve battery power.

Inserting/Removing the Batteries

Your instrument is shipped with six AA NICAD batteries already installed. Should you ever need to replace the batteries, first close and lock the Shoe (when the shoe is unlocked and open, it blocks the battery door). Next, slide the battery door in the rear of the instrument down and off. The batteries will spring out a bit.

To replace the batteries, insert six fresh AA NICAD batteries into the instrument, three into each chamber. **Note the proper polarity of the batteries in Figure 1-5, and on the CAUTION label beneath the instrument.** You will need to press and hold the batteries down in place while you slide the battery cover back on. Push the cover into place until it is flush with the bottom of the instrument.

Figure 1-5

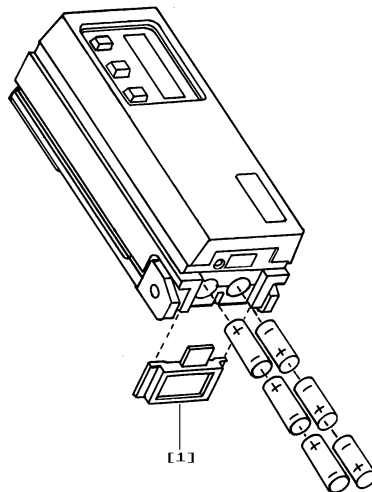

ADJUSTING THE DISPLAY ANGLE

You can most clearly read the LCD display by viewing it at a 90° angle. The angle of the display can be adjusted to accommodate this for different user sight lines.

To adjust the display angle:

1. Set the Display Angle Adjustment Knob on the right side of the instrument to its midpoint setting. (Figure 1-6)

Figure 1-6

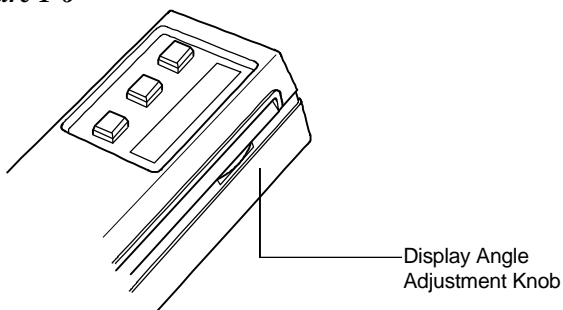

2. Activate the display by taking a measurement or pressing a control button.
3. Adjust the Display Angle Adjustment Knob until the displayed data can be most clearly seen from your line of sight.

I/O PORT SETUP

Your X-Rite 418 has a serial port that allows data to be transmitted to—or received from—an external device. With this I/O connection made, the 418 can be controlled externally by Serial Input Commands.

If you do not plan to use the I/O port at this time, you can skip ahead to Chapter 2, “Calibration.”

You can configure different functions of your I/O port using the instrument’s MODE selection procedures. You can set up:

- The desired Baud rate (output rate of characters per second) for transmitting data via the I/O port;
- the desired header (HDR) that will appear above the transmitted or printed data; and
- the desired computer output format (COMP).

To set up the I/O port:

1. Press the **FUNCTION** button and the **COLOR** button simultaneously, then release.

N cal T Y appears in the display, where “T” represents Status response (*T*, *G*, *E*, or *N*).

N cal T Y

2. Press **FUNCTION** to indicate no, you do not want to calibrate. *N mode Y* appears in the display.

N mode Y

3. Press **ZERO** to indicate yes, you do want to set mode. *^ RESP T* appears in the display.

^ RESP T

4. Press **FUNCTION** two times to advance the mode selection until *^ I/O Y* appears.

^ I/O Y

5. Press **ZERO**; *BAUD* plus a baud rate setting appears—either **OFF**, 300, 600, 1200, 2400, 4800, 9600. Press **ZERO** again to toggle to the next baud rate setting. Press repeatedly to toggle through all selections.

^BAUD 12>

6. When the desired baud rate setting appears, press **FUNCTION** to select the setting. *HDR ON* or *HDR OFF* appears in the display.

HDR ON

7. Press **ZERO** to toggle to the desired setting, either *HDR ON* or *HDR OFF*.

—When *HDR ON* is selected, a header will appear above transmitted or printed data indicating the data type—for example, **DEN** for density.

—When *HDR OFF* is selected, no header appears.

DEN
C 1.24
EXAMPLE: Header On

C 1.24
EXAMPLE: Header Off

8. When the desired setting appears in the display, press **FUNCTION** to select the setting. *COMP ON* or *COMP OFF* appears in the display.

COMP ON

9. Press **ZERO** to toggle to the desired setting, either *COMP ON* or *COMP OFF*.

—When *COMP ON* is selected, transmitted or printed data will simply be configured with single spaces between each measurement value.

—When *COMP OFF* is selected, transmitted or printed data will be configured in a “column” format, with a carriage return and line feed after each measurement value.

EXAMPLE: COMP On

DEN V0.67 C0.20 M1.23 Y0.77

EXAMPLE: COMP Off

DEN
V0.67
C0.20
M1.23
Y0.77

10. When the desired setting appears in the display, press **FUNCTION** three times to select the setting and return to normal operation.

RS232 Connector Interface

Your X-Rite 418 instrument can be connected to a computer or printer using a standard RS232 9-pin connector.

For more information on Serial Input Commands and remote control operation of the 418 order the Serial Interface Manual, P/N 418-506, from X-Rite, Incorporated.

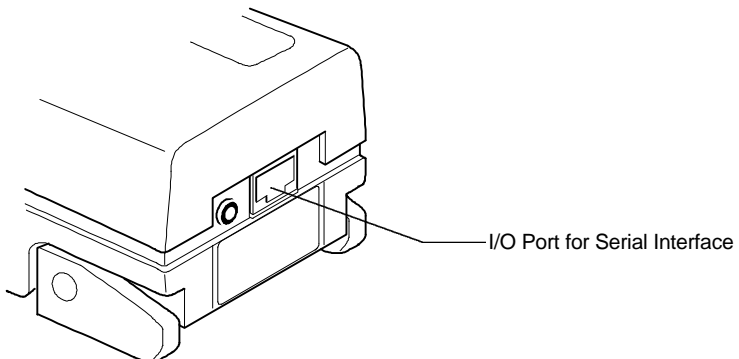

Response Settings	2-1
Overview of Calibration	
Procedures	2-3
Long Calibration.....	2-4
Color Correlation (CC)	
Calibration	2-7
Quick-Cal™	2-10

Frequency of Calibration

Under long operating conditions, the instrument should be calibrated once per week, or whenever the instrument displays a message regarding calibration. You should perform a “long calibration” whenever possible. However, you can also perform a Quick-Cal™ procedure any time after an initial long calibration has been performed.

Before calibrating, you should determine the appropriate densitometer response setting for your instrument, based on your production control requirements.

RESPONSE SETTINGS

A densitometer’s measurement system consists of several different components (lamp, optics, light sensor). Different densitometers consist of different types of these components. The density readings measured by these systems are called a *densitometer response*. Because components differ among densitometers, standard responses have been established in the industry. These standards ensure that even instruments with different components will measure in accordance with the same response.

With the complete set of optics—for version 418G and 418E—your versatile 418 instrument allows you to utilize four different densitometer response settings.

Descriptions of Available Responses

Using 418G optics, your 418 instrument can use the following responses:

- **Status T—ANSI Status T Computerized Color Response** is wideband response most typically used in the North American graphic arts industry. This status is used to calibrate the instrument to the T-Ref™ color reference.
- **Status G—X-Rite Graphic Arts Response** is a wideband response that is similar to Status T, except that it is more sensitive to denser yellow inks.

Using 418E optics, your 418 instrument can use the following responses:

- **Status E—European** utilizes the Wratten 47B filter—for higher readings in yellow—instead of the Wratten 47 filter typically used in North America.
- **Status I (displayed as Status N)—Narrow Band Glass Interference Type Computerized Color** response is computer corrected and designed for use with process inks on paper. Measurements other than process inks may produce measurement data with slight discrepancies. **NOTE:** The 418 displays this Status as Status *N*.

Selecting Response

To select the appropriate response:

1. First, if this is your first time selecting response, you should plug your instrument in using its AC adapter. This will prevent the microprocessor from going into “sleep” mode to save battery power. With the instrument plugged in, you’ll be free to take your time learning this procedure.
2. Press the FUNCTION button and the COLOR button simultaneously, then release. *N cal T Y* appears in the display, where “T” represents Status T response. The instrument is preset to “T” at the factory.

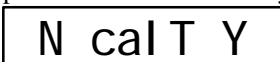

3. Press FUNCTION to indicate no, you do not want to calibrate. *N mode Y* appears.

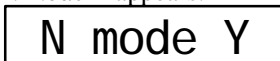

4. Press ZERO to indicate yes, you want to enter modes. \bar{RESP} T appears.

^ RESP T

5. Press ZERO again, then again to toggle the Status selection between T and G (for 418G), or E and N (for 418E). Stop when the desired response is displayed.
6. Press FUNCTION three times to return to the main display.

NOTE: Separate memory positions store calibration data for each of the four responses. If you change optics or change response setting, you must re-calibrate using that response.

You do not need to re-calibrate when you switch to a response for which you have already calibrated.

OVERVIEW OF CALIBRATION PROCEDURES

Calibrating your instrument is crucial to maintaining its measurement stability. It is also important to maintaining measurement agreement between several densitometers at the same site; and making all densitometers calibrate precisely to the same standard reference, such as T-Ref. Your 418 instrument's Computerized Color Response™ allows you to use one of three different calibration procedures to address these factors:

1. **Long Calibration** allows you to calibrate your instrument to any color reference. This procedure will be used before you take your first measurements for each response. After this calibration procedure has been performed, you can use Quick-Cal™ (see below) to quickly re-calibrate when necessary.
2. **Color Correlation Calibration** allows you to set the 418 to measure in agreement with another densitometer that has the same response (for example, two wideband densitometers).
3. **Quick Cal™** allows you to quickly re-calibrate to white without having to re-measure the black and/or color patches.

LONG CALIBRATION

1. If this is your first time calibrating, you should plug your instrument in using its AC adapter. This will prevent the microprocessor from going into “sleep” mode to save battery power. With the instrument plugged in, you’ll be free to take your time learning this procedure.
2. Unlock the Shoe.
3. Press the **FUNCTION** and **COLOR** buttons simultaneously until *N cal T Y* appears in the display. *T* stands for the default Status T Response; if you have a different response selected, its initial letter will appear in this position. (See “Selecting Response” earlier in this chapter.)

N cal T Y

4. Press **ZERO** to indicate Yes, you do want to calibrate.

N Qcal Y

5. Press **FUNCTION** to select long calibration. *SET LO* appears in the display for a moment.

SET LO

6. At this point, refer to the front of your Color Reflection Reference Envelope. (Figure 2-1)

The first value that appears in the display should match the visual (“V”) value for the T Response printed on your envelope under:

STEP 1 (WHITE)	CAL-LO
T V0.07 C0.06 M0.07 Y0.10	
G V0.07 C0.06 M0.07 Y0.10	

Tv 0.07L

NOTE: Values shown above and in Figure 2-1 are examples—your values may be different.

Figure 2-1

X-Rite®
 Color Reflection Reference
 P/N 418-62
 Serial No. C9647103S-35619

Polarization NOT INCLUDED

STEP 1 (WHITE)	CAL-LO
T V0.07 C0.06 M0.07 Y0.10	
G V0.07 C0.06 M0.07 Y0.10	
E V0.07 C0.06 M0.07 Y0.12	
I V0.07 C0.05 M0.07 Y0.12	

STEP 2 (GREY)	LINEARITY
V0.91	

STEP 3 (BLACK)	CAL-HI
V1.92	

STEP 4 (CYAN)	CAL-HI
T C1.35	
G C1.35	
E C1.35	
I C1.39	

STEP 5 (MAGENTA)	CAL-HI
T M1.60	
G M1.60	
E M1.60	
I M1.73	

STEP 6 (YELLOW)	CAL-HI
T Y1.31	
G Y1.50	
E Y1.80	
I Y1.83	

IMPORTANT! The density values on this reference are affected by its cleanliness. Higher densities are dramatically affected by smudge marks, dust, and fingerprints. Use a clean, lint-free cloth to clean the reference. Place it in the envelope when not in use.

418 Color Reflection Densitometer

7. If the values on the envelope and on the display do not match, enter the correct value using the blue and red arrow buttons.

To lower the value:

Press and hold the ZERO (ts) button, then press FUNCTION (t) repeatedly to lower the value until the correct value is shown.

To raise the value:

Press and hold the ZERO (ts) button, then press COLOR (s) repeatedly to raise the value until the correct value is shown.

TIP: If you need to move the value up or down by a large amount, hold the (ts) button and (t) or (s) button down. The numbers will advance faster as you hold it down.

8. Release all buttons, then press COLOR. The T Response value for cyan (C) appears. It should match the value printed on your Reference Envelope.

STEP 1 (WHITE)	CAL-LO
T V0.07 C0.06 M0.07 Y0.10	
G V0.07 C0.06 M0.07 Y0.10	

Tc 0.06L

9. If the values on the envelope and on the display do not match, use the blue and red arrow buttons as specified in #7 to enter the correct value.
10. Follow #8 again for magenta (M), and then again for yellow (Y).
If the envelope and display values do not match for either color, follow #7 to correct.
11. Press COLOR again. *SET HI* appears for a moment. Then, the Step 3 (Black) CAL-HI value for the T Response appears.

(Figure 2-1)
SET HI

Tv 1.92H

12. If the values on the envelope and on the display do not match, use the blue and red arrow buttons as specified in #7 to enter the correct value.
13. Repeat #11 for Step 4 (cyan), Step 5 (magenta), and Step 6 (yellow). Follow #7 if you need to correct the values. (Figure 2-1)

- Press COLOR again. *READ WHT* appears.

READ WHT

- Take your Color Reflection Card out of the envelope. Lay it on a flat, steady surface with the color target side facing up. (Figure 2-2)

Figure 2-2

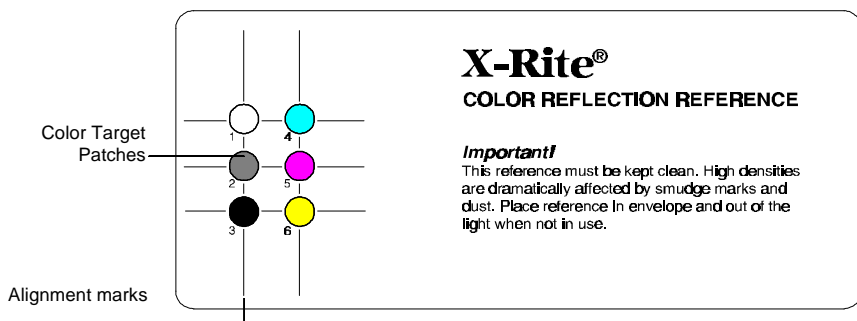

- Read Step 1—the white target patch—by placing the instrument target window cross-hairs over the alignment marks, then lowering the head down onto the shoe. One of the filter values for Step 1 appears in the display, then *READ BLK* (BLACK) appears.

v 0.06L

READ BLK

- Read Step 3—the black target patch (*not* Step 2, the gray patch). One of the filter values for Step 3 appears in the display, then *READ CYAN* appears.
- Repeat these measurement steps for Step 4 (cyan), Step 5 (magenta), and Step 6 (yellow).

The values that appear for each Step measurement should match the values listed on the envelope for that Step. If they do not, repeat the calibration procedure. If discrepancies continue to exist, contact X-Rite Instrument Services.

If all values were correct, your instrument is calibrated!

If you wish to calibrate to make your instrument measure in agreement with another instrument, perform the following procedures for “Color Correlation Calibration.”

COLOR CORRELATION (CC) CALIBRATION

There are two ways to perform color correlation calibration, which creates measurement agreement between your 418 and another, similar instrument. The method you use depends on the type of calibration reference used by the other instrument.

NOTE: Color correlation between two instruments can best be achieved between two very similar instruments—two that utilize the same Status setting, have the same optics type, aperture size, and polarization (both have—or both do not have—polarization filters).

If the other instrument uses a reference similar to the 418's—with black, white, cyan, magenta, and yellow ink targets on paper—then use the first set of instructions. If the other instrument uses a reference without CMYK patches—such as a ceramic plaque with white and black only—then use the second set of instructions.

CC Using Master Instrument CMYK Target

1. Calibrate the other, “master” instrument according to its manufacturer’s specifications and instructions.
2. Begin a long calibration procedure for your 418 instrument (see previous section).
3. When you go to verify the calibration values on the calibration reference envelope, *use the values for the master instrument’s calibration standard, instead.* Use the procedure in #7 of the long calibration instructions to modify the values on your instrument display to match those on the master instrument’s envelope or reference.
4. When calibration is due for either instrument, use *the master instrument’s calibration reference.*

CC with No Master Instrument CMYK Target

1. Get a pen or pencil and piece of paper ready.
2. Calibrate the master instrument according to its manufacturer's specifications and instructions.
3. Prepare the master instrument to read low density (white CAL-LO).
4. Measure Step 1 (white) on the 418's calibration reference using the master instrument. *Write down* the low density values for visual, cyan, magenta, and yellow.
5. Prepare the master instrument to read high density (black CAL HI).
6. Measure Step 3 (black) on the 418's calibration reference using the master instrument. *Write down* the high density values for visual, cyan, magenta, and yellow.
7. Prepare the master instrument to read color patches.
8. Read Steps 4, 5, and 6 (cyan, magenta, and yellow) on the 418's calibration reference using the master instrument. *Write down* the density values for each color.
9. Begin a long calibration using your 418 instrument. When you go to set the CAL LO values, verify the visual, cyan, magenta, and yellow values against the low density values you measured with the *master instrument*. Use the arrow buttons to adjust the values (see #7 of the last section).
10. Press COLOR again to advance to setting the CAL HI values. Verify the visual, cyan, magenta, and yellow values against the high density values you measured with the *master instrument*. Use the arrow buttons to adjust the values (see #7 of the last section).
11. When you enter the last "CAL HI" value, the instrument recognizes that you have entered measured black values for each color filter. *N col- Y* appears in the display, asking if you wish to perform a color correlation calibration.
12. Press COLOR to indicate yes, you do want to perform a color correlation calibration.

418 Color Reflection Densitometer

13. *SET cmy* appears briefly in the display, followed by the CAL-HI value for cyan. Verify the cyan value against the cyan value you measured with the *master instrument*. Use the arrow buttons to adjust the value (see #7 of the last section).
14. Verify the magenta and yellow values against the values measured with the master instrument, then adjust the values to match the master values as necessary.
15. *READ WHT* appears in the display. Measure white, then verify that the value matches the values recorded for each master instrument measurement. The display prompts you to measure Steps 3, 4, 5, and 6. Verify that these values match the master instrument's measurements, as well.
16. Perform future calibrations of your 418 using this procedure.

QUICK CAL™

Once you have performed the long calibration, you can simply perform the Quick Cal™ procedure periodically to set the low density (white) value.

NOTE: In most cases, you should simply perform an entire long calibration if possible.

1. Press **FUNCTION** and **COLOR** simultaneously, then release. *N cal T Y* appears in the display. T stands for the default Status T Response; if you have a different response selected, its initial letter will appear in this position. (See “Selecting Response” earlier in this chapter.)
2. Press **ZERO** to indicate yes, you do want to calibrate.
3. Press **ZERO** to select Quick Cal™ procedure.
4. Read Step 1—the white patch—on the reference card.

Your instrument is calibrated!

3

Electronic Function Selection

EFS Measurement..... 3-2

The EFS™ (Electronic Function Selection) function will electronically recognize a measurement as density, dot, or trap without changing functions.

Upon entry into EFS, paper must be measured. Next, solid densities for each color are measured. Further measurements can now be solids, tones, or overprints.

If *-R*, reference, or *GAIN* is enabled or disabled for density, dot, trap, or print contrast, it will remain that way in the EFS function.

NOTE: The 418 uses a variable threshold (based on the solid density) to determine if a measurement is a solid density or a tone used to calculate dot. If a desired tone area measurement is displayed as a solid density, momentarily press **ZERO** before releasing the head. The dot value is displayed and the solid density is not updated.

EFS MEASUREMENT

1. Repeatedly press **FUNCTION** until *EFS* is displayed.

EFS

2. Once *PAPER* is displayed, measure the paper
 - If the instrument recognizes the measurement as a paper reading, the display becomes ready for the first color reading.
 - If the instrument does not recognize the measurement as a paper reading, *PAPER? Z* appears.

PAPER? Z

3. Once *SOLID* is displayed, measure either the solid or overprint.
 - For overprint, continue with the Trap Measurement procedure. (page 6-5)
 - For solid, continue measuring the various dot values of the same color.

NOTE: After performing one of the above operations, a different trap, solid, or tone can be measured next. Also, to update a paper value at any time, press **ZERO** while measuring paper.

Selecting Density Function.....	4-2
Selecting Density Mode	4-3
Selecting Color Measurement Method	4-5
Density Measurement	4-6
Density Difference Measurement.....	4-8

For density measurement, you need to set some measurement parameters. You need to select:

- the desired measurement *function* (density) (page 4-2);
- the desired density measurement *mode*—absolute density, or density minus paper (page 4-3); and
- the desired color measurement *method*—*SINGLE*, *AUTO*, or *ALL* (page 4-5).

These parameters must be set for all types of density measurement. Once these parameters are set, you can set your instrument to evaluate measurement data two different ways:

- As a straight *density measurement* data. Viewing this data requires no additional setup (page 4-6).
or
- As a *density difference measurement* data. This data shows you the amount of difference between the measured density and a pre-set reference density. To view data in this format, you need to establish a reference measurement, and set up the instrument for density difference readings (page 4-8).

SELECTING DENSITY FUNCTION

1. If this is your first time selecting a measurement function and mode, you should plug your instrument in using its AC adapter. This will prevent the microprocessor from going into “sleep” mode to save battery power. With the instrument plugged in, you’ll be free to take your time learning this procedure.
2. Next, make sure you have the desired response setting selected, and that the instrument is properly calibrated. These procedures are covered in chapter 2, “Calibration.”
3. To select the measurement method for measuring ink density, press the **FUNCTION** button repeatedly until *DEN* appears in the display.

DEN

Now, you can choose to measure *absolute density*, which reads the ink density *including* the paper; or to measure density *minus paper*. You make this selection by setting density mode.

SELECTING DENSITY MODE

1. Press the FUNCTION button and the COLOR button simultaneously, then release. *N cal T Y* appears in the display, where “T” represents Status response you selected (*T*, *G*, *E*, or *N*).

N cal T Y

2. Press FUNCTION to indicate no, you do not want to calibrate. *N mode Y* appears in the display.

N mode Y

3. Press ZERO to indicate yes, you do want to set mode. $\bar{\wedge}$ *RESP T* appears in the display.

$\bar{\wedge}$ RESP T

4. Press FUNCTION to advance to mode selection. *DEN-P* or *DEN AB* appears in the display.

DEN AB

5. Here is where you select *density minus paper* or *absolute density*.

—If you wish to select *density minus paper*, press ZERO until *DEN-P* appears in the display. Then, simply press FUNCTION until you exit mode selection. Density minus paper mode is already selected; *DEN-P* appears in the display briefly, followed by *PAPER*.

—If you wish to select *absolute density*, press ZERO until *DEN AB* appears in the display. Then, simply press FUNCTION until you exit mode selection. Absolute density mode is already selected; *DEN AB* appears in the display briefly, followed by a color value for visual, cyan, magenta, or yellow.

Measurement mode is now selected. Absolute density measurement data will appear with a “D” after the value; Density minus paper data will appear with an underlined “D”.

]v 0.13D

Indicates absolute density

]v 0.13D

Indicates density minus
paper

Measuring PAPER for DEN-P Mode

When you select *density minus paper* as the measurement mode, you must provide a reading of the paper before taking color measurements. The instrument will take the density value of the paper and automatically subtract it from subsequent color measurements. This paper value must be updated before every measurement sequence.

Once *density minus paper (DEN-P)* mode is selected, *PAPER* appears in the display. Center the instrument target window over a sample of the paper, then lower the instrument head to take a reading and hold.

PAPER

- If the instrument recognizes the measurement as a paper reading, the display becomes ready for the first color reading.
- If the instrument does not recognize the measurement as a paper reading, *PAPER? Z* appears.

PAPER? Z

Keep the instrument pressed down, then press ZERO to indicate that yes, this is the new paper value. Then, the display becomes ready for the first color reading.

]v 0.13(

SELECTING COLOR MEASUREMENT METHOD

You can choose from three different measurement methods using the density function:

- *SINGLE* measurement method simply measures and updates the specific color you selected.
- *AUTO* measurement method measures all four colors, then simply updates and displays the most dominant color.
- *ALL* measurement method measures and updates all four colors, and displays the most dominant color.

To select color measurement method:

1. Press **FUNCTION** until *DEN* appears in the display. After a moment, the **CAL LO** value for one of the colors—visual (*v*), cyan (*c*), magenta (*m*), or yellow (*y*)—appears in the display.

v 0.13(

2. Press and hold **COLOR**. One of the color measurement methods—*SINGLE*, *AUTO*, or *ALL*—appears in the display. If the method you want appears, simply wait a moment and the color values will appear again.

SINGLE

3. If you wish to change the color measurement method, press **COLOR** again, then again to toggle from one method to the next. When the desired method appears, simply wait a moment and the color values will appear again. The color measurement method is set.

Determining which Method is Active

The active color measurement method is indicated at the far left when color measurement information appears in the display:

- When *SINGLE* is active, no characters are shown at the far left.
- When *AUTO* is active, the characters “A” and “u” appear to the far left of the display .

[v 0.13(

]v 0.13(

- When *ALL* is active, the characters “A” and “ll” appear to the far left of the display.

DENSITY MEASUREMENT

So far, you have performed the procedures to select density function, mode, and color measurement method.

You are now ready to begin taking measurements to check density values on your press sheet color bar. The type of measurement data that will be displayed will depend on the way you set up your instrument earlier in this chapter. However, for all functions, modes, and methods, the measurement technique is the same. Simply:

1. Center target window over area to be measured.
2. Lower unit to target window and hold closed.
3. Once measurement data is displayed, release the unit.
4. Measurement data will appear either as a normal density value (absolute or minus paper) or difference value.

Viewing Density Measurement Data

There are several different combinations of mode and method settings that will affect the way the measurement data is displayed. Since you just set up these parameters yourself, you should see the data in the format you expect. For example, if you set your instrument parameters to *AUTO* and *-PAPER*, your measurement data will appear like this:

[c 1.13(

“A” and “u” appear to the far left, indicating that the instrument automatically recognized the color—in our example, the color was cyan. And, the “D” after the value is underlined for density minus paper measurements; not underlined for absolute density measurements.

Viewing Measurement Data for Each Color

You can view measurement data in the display for one color at a time. To toggle the display view from one color's measurement data to the next, press the COLOR button when data is displayed. Each time you press, the display switches from visual to cyan to magenta, and so forth.

[v 1.13(

[c 1.17(

[m 1.18(

[y 1.02(

EXAMPLE: Pressing the COLOR button repeatedly toggles display from one color's measurement data to the next.

If you are using the SINGLE or AUTO measurement method, the data displayed for each color represents the last time that color was measured. If you are using the ALL method, each color's data represents the amount of that color measured in the last color read. The most dominant color will have the highest density reading.

]v 0.67D

]c 0.20D

]m 1.23D

]y 0.77D

EXAMPLE: Using the ALL measurement method, all color data is derived from the single most recent measurement. In our example, magenta is the most dominant color.

DENSITY DIFFERENCE MEASUREMENT

Density difference measurement uses the same parameters as density measurement. To set up for density difference measurement, follow the procedures earlier in this chapter for selecting density function, mode, and color measurement method.

To view measurement data as a density difference value between a measured sample and a known reference—instead of the density value of the measured sample—you must first enter a reference measurement; and then activate the density difference (*DEN-R* or *DEN-P-R*) display format.

Entering a Reference Measurement

1. Press **FUNCTION** until *DEN* appears in the display. After a moment, a color value for one of the colors appears in the display.
2. Press **ZERO**. *REF* appears for a moment, followed by the current Reference value. If none has been entered, the Reference value is *0.00*.
3. To enter a reference value—or change the current reference value—you can either:
 - measure the reference value directly; or
 - manually enter the reference value using the arrow button functions.

To measure the reference value directly:

Measure the color that you wish to use as the reference. Then, press **FUNCTION** to return to normal operation.

To enter the reference value manually:

Hold down the **ZERO** (▼▲) button, then press the **FUNCTION** (t) or **CAL** (s) button to adjust the value until the desired value is shown. Then, press **FUNCTION** to return to normal operation.

TIP: If you need to move the value up or down by a large amount, hold the arrow button down. The numbers will advance faster as you hold it down.

Activating Density Difference Display Format

Once you have your reference measurement established and stored in the instrument's memory, you now simply need to activate the density difference display format:

1. When you press **FUNCTION** and *DEN* or *DEN-P* appears, press **ZERO** before the display switches to *PAPER* or the first color value. *-R* is added to the function. The display reads as either *DEN-R* if you are in *absolute* mode; or *DEN-P-R* if you are in *minus paper* mode.
2. To de-activate density difference display format, repeat #1 to remove *-R* from the function.

Viewing Density Difference Measurement Data

There are several different combinations of mode and method settings that will affect the way the measurement data is displayed. Since you just set up these parameters yourself, you should see the data in the format you expect. For example, if you set your instrument parameters to *AUTO* and *-PAPER*, your measurement data will appear like this:

[c -0@13(

“A” and “u” appear to the far left, indicating that the instrument automatically recognized the color—in our example, the color was cyan. And, the “D” after the value is underlined for density minus paper measurements; not underlined for absolute density measurements. The “r” above the decimal point indicates that this is a density-minus-reference measurement.

A “negative” value indicates that the sample was measured to have less density than the reference. If a positive value appears, the sample was measured to have more density than the sample. If *0.00* appears, the sample was measured to have the same density as the reference.

Selecting Dot Area or Dot Gain .	5-2
Selecting Measurement Method	5-3
Dot Area Function.....	5-4
Dot Gain Function.....	5-6

For dot measurements, you need to set some measurement parameters. You need to select:

- the desired measurement *function*—dot *area* or dot *gain* (page 5-3); and
- the desired color measurement *method*—*SINGLE* or *AUTO* (page 5-4)
- **NOTE:** All dot function measurements are minus paper.

Dot is calculated using the the Murray-Davies formula. The Murray-Davies simply calculates dot by comparing the density of the tint minus paper with the density of the solid minus paper.

The Murray-Davies formula for calculating Dot is:

$$\text{Apparent Dot Area} = \frac{1 - 10^{-(D_t)}}{1 - 10^{-(D_s)}} \times 100$$

Where: D_t = Density of tint minus density of paper

D_s = Density of solid minus density of paper

SELECTING DOT AREA OR DOT GAIN

1. If this is your first time selecting a measurement function, you should plug your instrument in using its AC adapter. This prevents the microprocessor from going into “sleep” mode to save battery power. With the instrument plugged in, you’ll be free to take your time learning this procedure.
2. Next, make sure you have the desired response setting selected, and that the instrument is properly calibrated. These procedures are covered in chapter 2, “Calibration.”
3. To select the measurement method for measuring ink density, press the **FUNCTION** button repeatedly until *DOT AREA* or *DOT GAIN* appears in the display.

DOT AREA

DOT GAIN

4. If *DOT AREA* appears and you wish to select *DOT GAIN*, press and release the **ZERO** button to toggle the selection. Do the same if *DOT GAIN* appears and you wish to select *DOT AREA*.

SELECTING COLOR MEASUREMENT METHOD

You can choose from two different measurement methods using the dot function:

- *SINGLE* measurement method simply measures and updates the specific color you selected.
- *AUTO* measurement method measures all four colors, then simply updates and displays the most dominant color.
- **NOTE:** *ALL* is not used for dot measurements.

To select color measurement method:

1. Press **FUNCTION** until *DOT AREA* or *DOT GAIN* appears in the display. After a moment, *PAPER* appears in the display.
2. Press **ZERO**. A dot area or dot gain value for one of the colors—visual (*v*), cyan (*c*), magenta (*m*), or yellow (*y*)—appears in the display.

[c 100 %]

3. Press and hold **COLOR**. One of the color measurement methods—*SINGLE* or *AUTO*—appears in the display. If the method you want appears, simply wait a moment and the color values will appear again.

SINGLE

3. If you wish to change the color measurement method, press **COLOR** again, then again to toggle from one method to the next. When the desired method appears, simply wait a moment and the color values will appear again.

Color measurement method is set.

Determining which Method is Active

The active color measurement method is indicated at the far left when color measurement information appears in the display:

- When *SINGLE* is active, no characters are shown at the far left.
- When *AUTO* is active, the characters “A” and “u” appear to the far left of the display.

([v 0.13(

DOT AREA FUNCTION

Once dot area measurement (*DOT AREA*) mode is selected, *PAPER* appears in the display.



- Center the instrument target window over a sample of the paper, then lower the instrument head to take a reading and hold.

—If the instrument recognizes the measurement as a paper reading, the display flashes *DOT T* (or *DOT G*, or *DOT E*, and so forth) momentarily, then becomes ready for the first *SOLID* reading.

—If the instrument does not recognize the measurement as a paper reading, *PAPER? Z* appears.



Keep the instrument pressed down, then press **ZERO** to indicate that yes, this is the new paper value. Then, the display becomes ready for the first *SOLID* reading.



- Measure the solid patch. *DOT T* is displayed during measurement, then the measurement data appears.

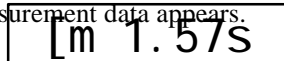
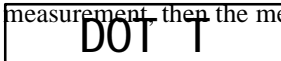

If Solid is displayed as a Dot value (a percentage, such as *m 94%*) instead of a solid density value (such as *m 1.57s*), hold the instrument closed and press **ZERO**.

If *SOLID? Z* is displayed, press **ZERO** to measure as a Solid, then release the instrument.

NOTE: Solid density is displayed minus paper.

3. Read a tint of the solid color you just measured. During measurement, *DOT T* is displayed. Then, the Dot value is displayed.

DOT T

[m 75 %

4. Measure additional tints of that color. The instrument automatically recognizes the measurements as tint values and displays the tint percentage.
5. When you are ready to measure another color, simply measure the solid and repeat the procedures beginning with #2. The instrument automatically recognizes the measurement as a solid. Also, you do not need to enter a new paper measurement.

DOT GAIN FUNCTION

Dot gain measurement compares the tint percentage of a color patch on paper to the intended tint percentage produced on the film.

Your instrument is preset at the factory to use the standard tint percentages for color bar patches as the four measurement reference values:

Factory presets for 418G

- Reference 1 (r1) is 25%
- Reference 2 (r2) is 50%
- Reference 3 (r3) is 75%

Factory presets for 418E

- Reference 1 (r1) is 40%
- Reference 2 (r2) is OFF
- Reference 3 (r3) is 80%

Your first dot gain measurement compares the dot percentage of the measured patch to the first reference value (r1). The difference between the reference value and the measured value is calculated as dot gain—the amount the ink dots have spread on the paper.

If needed, you can adjust the Reference values to meet your specific needs. These procedures are covered next. If you wish to simply use the factory preset reference values, you can skip ahead to “Dot Gain Measurement.”

Adjusting Dot Gain Reference Values

Once dot gain measurement (*DOT GAIN*) mode is selected, *PAPER* appears in the display.

PAPER

1. Press **ZERO** two times. *REF* appears in the display momentarily, followed by one of the reference values—either r1, r2, or r3.

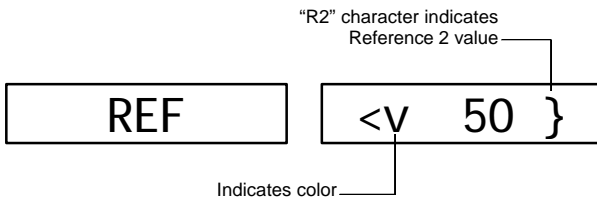

2. To select the desired color at the current reference value, press **COLOR** to toggle between *v*, *c*, *m*, and *y*. The factory presets should show the same value for each color. (You can enter a different value for each color if you like.)

- When the color and reference value you wish to change appear in the display, use **ZERO** (t_s), **COLOR** (s), and **FUNCTION** (t) buttons to adjust the value.

—Press and hold **ZERO**, then press **COLOR** (s) to raise the value;

—Press and hold **ZERO**, then press **FUNCTION** (t) to lower the value.

When you change the preset values, they are turned “off.” Your new reference values can be set within the following ranges.

—r1 can be set between 1% and 45%.

—r2 can be set between 46% and 64%

—r3 can be set between 65% and 100%

These value ranges apply to 418G and 418E instruments.

- Advance to the next color, then repeat #3; or press **ZERO** to advance to the next reference value, either r1, r2, or r3.

<v	75	{
----	----	---

Repeat #3 and #4 until all reference values are set to your preferences.

- Press **FUNCTION** to return to dot gain measurement mode. Measurements at each tint will be compared to the appropriate reference value.

Dot Gain Measurement

Once dot gain measurement (*DOT GAIN*) mode is selected, *PAPER* appears in the display.



1. Center the instrument target window over a sample of the paper, then lower the instrument head to take a reading and hold.

—If the instrument recognizes the measurement as a paper reading, the display flashes *DOT T* (or *DOT G*, or *DOT E*, and so forth) momentarily, then becomes ready for the first *SOLID* reading.

—If the instrument does not recognize the measurement as a paper reading, *PAPER? Z* appears.



Keep the instrument pressed down, then press **ZERO** to indicate that yes, this is the new paper value. Then, the display becomes ready for the first *SOLID* reading.



2. Measure the solid patch. *DOT T* is displayed during measurement, then the measurement data appears.

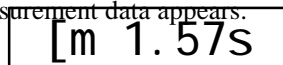

If Solid is displayed as a Dot value (a percentage, such as *m 94%*) instead of a solid density value (such as *m 1.57s*), hold the instrument closed and press **ZERO**.

If *SOLID? Z* is displayed, press **ZERO** to measure as a Solid, then release the instrument.

NOTE: Solid density is displayed minus paper.

3. Read the first tint of the solid color you just measured. This should be the color patch with the lowest tint percentage, such as the 25% patch. During measurement, *DOT T* is displayed. Then, the Dot Gain value is displayed.

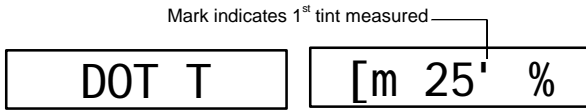

A mark before the percentage symbol indicates which tint percentage in the sequence has been measured.

4. Measure the remaining tints of that color. The instrument automatically recognizes the measurements as tint values and displays the dot gain value for that tint. Display marks indicate which tint percentage in the sequence has been measured.

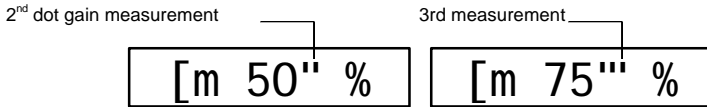

Trap Formulas	6-1
Selecting Trap Function	6-3
Trap Measurement.....	6-5
Trap Difference Measurement.	6-8
Trap DMAX Entry.....	6-10

Trap determines how well one ink prints over another ink (overprinting). For trap measurements, you need to set some measurement parameters. You need to select:

- The desired formula for trap measurements—the *Preucil (GATF)* formula, the *Brunner* formula, or the *Newsprint* formula (page 6-1); and
- the desired measurement *function*—*trap* or *trap reference* (page 6-3).
- **NOTE:** All trap function measurements are minus paper and AUTO only.

TRAP FORMULAS

Trap is electronically calculated after measurements of the overprint, second ink printed, and the first ink printed.

The Preucil (GATF) formula (factory enabled) is:

$$T_p = \frac{D_{OP} - D_1}{D_2} \times 100$$

The Brunner Trap formula is:

$$T_B = \frac{1 - 10^{-D_{Op}}}{1 - 10^{-(D_1 + D_2)}} \times 100$$

The Newsprint Trap formula is:

$$T_N = \frac{\log\left(1 + \frac{D_{OP} - D_1}{D_M - D_{OP}}\right)}{\log\left(1 + \frac{D_2}{D_M - D_2}\right)} \times 100$$

Where:

- D_{OP} = Density of overprint - paper
- D_2 = Density of 2nd ink - paper
- D_1 = Density of 1st ink - paper
- D_M = Maximum printing density

Selecting Preucil (GATF) Formula

If you wish to use the Preucil (GATF) formula, you do not have to make any modifications to the factory-preset mode settings.

Selecting Brunner or Newsprint Formulas

To select the Brunner or Newsprint trap formula:

1. Press the **FUNCTION** button and the **COLOR** button simultaneously, then release. *N cal T Y* appears in the display, where “T” represents Status response you selected (*T*, *G*, *E*, or *N*).

N cal T Y

2. Press **FUNCTION** to indicate no, you do not want to calibrate. *N mode Y* appears in the display.

N mode Y

3. Press **ZERO** to indicate yes, you do want to set mode. \wedge *RESP T* appears in the display.

\wedge RESP T

4. Press **FUNCTION** four times to advance the mode selection until \wedge *TRAP* appears.

\wedge TRAP

5. Press **ZERO** until \wedge *TRAP B* appears for Brunner formula or \wedge *TRAP N* appears for Newsprint formula.

Bunner formula:

\wedge TRAP B

Newsprint formula:

\wedge TRAP N

6. Press **FUNCTION** until the instrument returns to normal operation.

SELECTING TRAP FUNCTION

1. If this is your first time selecting a measurement function, you should plug your instrument in using its AC adapter. This will prevent the microprocessor from going into “sleep” mode to save battery power. With the instrument plugged in, you’ll be free to take your time learning this procedure.
2. Next, make sure you have the desired response setting selected, and that the instrument is properly calibrated. These procedures are covered in the chapter 2, “Calibration.”
3. To select the measurement method for measuring trap, press the **FUNCTION** button repeatedly until *TRAPX* appears in the display. (Each time you press the **ZERO** button the display toggles between *TRAPX* and *TRAPX-R*—where *X* represents the trap formula: *B* = Brunner; *N* = Newsprint; no *X* = Preucil.)

For Trap measurement:

TRAP

For Trap Reference measurement:

TRAP-R

Measuring PAPER for Trap

When measuring trap, you must provide a reading of the paper before taking color measurements. The instrument will take the value of the paper and automatically subtract it from subsequent color measurements. This paper value must be updated before every measurement sequence.

Once *PAPER* appears in the display. Center the instrument target window over a sample of the paper, then lower the instrument head to take a reading and hold.

PAPER

- If the instrument recognizes the measurement as a paper reading, the display becomes ready for the first color reading.
- If the instrument does not recognize the measurement as a paper reading, *PAPER? Z* appears.

PAPER? Z

Keep the instrument pressed down, then press ZERO to indicate that yes, this is the new paper value. Then, the display becomes ready for the first color reading.

] y 0.10P

TRAP MEASUREMENT

So far, you have performed the procedures to select the correct trap formula, trap function, and measured the paper.

You are now ready to begin taking measurements to check trap values on your press sheet color bar. The type of measurement data that will be displayed will depend on the way you set up your instrument earlier in this chapter.

Preucil and Brunner Measurements

For the Preucil (GATF) and Brunner formulas, the measurement technique is the same.

1. After the paper measurement is taken, *O.P.* is displayed. To enter a reference measurement, see the Trap Difference Measurement section.

O. P.

2. Center target window over the overprint patch.
3. Lower unit to target window and hold closed.
4. Once overprint data is displayed, release the unit. If the patch being measured is not an overprint, *READ OP* is displayed, followed by the most dominant ink.
5. Once the unit is released, *2ND INK* is displayed.

2nd INK

6. Center target window over the patch for the second ink down.
7. Lower unit to target window and hold closed.
8. Once 2nd ink data is displayed, release the unit. *1ST INK* is displayed.

1st INK

9. Center target window over the patch for the first ink down.
10. Lower unit to target window and hold closed.
11. Once trap data is displayed, release the unit. The calculated trap value is displayed for overprint.

Newsprint Measurements

For the Newsprint formula, follow this measurement technique.

1. After the paper measurement is taken, *DMAX O.P.* is displayed. To enter a reference measurement, see the Trap Difference Measurement section.

$DMAX^{\wedge} \quad \begin{matrix} 0^{\wedge} \\ P \end{matrix}$

2. Either press **COLOR** to enter *DMAX* or press **ZERO** to display *O.P.* *DMAX* can be automatically calculated by simply measuring the solid patches or it can be manually entered. See the “Trap *DMAX* Entry” section.
3. Center target window over the overprint patch.
4. Lower unit to target window and hold closed.
5. Once overprint data is displayed, release the unit. If the patch being measured is not an overprint, *READ OP* is displayed, followed by the most dominant ink.
6. Once the unit is released, *2ND INK* is displayed.

2nd INK

7. Center target window over the patch for the second ink down.
8. Lower unit to target window and hold closed.
9. Once 2nd ink data is displayed, release the unit. *1ST INK* is displayed.

1st INK

10. Center target window over the patch for the first ink down.
11. Lower unit to target window and hold closed.
12. Once trap data is displayed, release the unit. The calculated trap value is displayed for overprint.

Viewing Trap Measurement Data

Trap value color is displayed as color over color at the far left—v (visual), c (cyan), m (magenta), y (yellow)—followed by the trap value and formula designation.

Y	84. ^r 3T
C	

For example, “Y” above “C” appearing to the far left, yellow is the second ink down and cyan is the first ink down. The “r” indicates that the measurement was a trap reference measurement. The “T” indicates the Preucil formula for calculating trap, “T” above “b” would indicate Bunner formula, and “T” above “n” would indicate Newsprint formula.

TRAP DIFFERENCE MEASUREMENT

Trap difference measurement uses the same parameters as trap measurement. To set up for trap difference measurement, follow the procedures earlier in this chapter for selecting trap function and formula.

To view measurement data as a trap difference value between a measured sample and a known reference—instead of the trap value of the measured sample—you must first enter a reference measurement; and then activate the trap difference (*TRAP-R*) display format.

Activating Trap Difference Display Format

Once you have your reference measurement established and stored in the instrument's memory, you now simply need to activate the print contrast difference display format:

1. When you press **FUNCTION** and *TRAP* appears, press **ZERO** before the display switches to *PAPER* or the first color value. *-R* is added to the function. The display reads *TRAP-R*.
2. To de-activate density difference display format, repeat #1 to remove *-R* from the function.

Entering a Reference Measurement

1. Before measuring your overprint, press **ZERO** twice. *REF* appears for a moment, followed by the current Reference value. If none has been entered, the Reference value is *0.00*.
2. Select ink combinations—the second ink is displayed on top (yellow is 2nd ink and cyan is 1st ink in example below)—by pressing **COLOR**.

$\begin{matrix} <^Y \\ <_C \end{matrix} 72.3R$
--

3. To enter a reference value—or change the current reference value—you can either:
 - measure the reference value directly; or
 - manually enter the reference value using the arrow button functions.

To measure the reference value directly:

Measure the overprint, second ink, and first ink that you wish to use as the reference. Then, press **FUNCTION** to return to normal operation.

To enter the reference value manually:

Hold down the **ZERO (▼▲)** button, then press the **FUNCTION (†)** or **CAL (§)** button to adjust the value until the desired value is shown. Then, press **FUNCTION** to return to normal operation.

TIP: If you need to move the value up or down by a large amount, hold the arrow button down. The numbers will advance faster as you hold it down.

TRAP DMAX ENTRY

Trap DMAX can be either automatically calculated or manually entered.

Automatic Calculation

DMAX is automatically calculated by simply measuring the solid patches as shown below.

1. Once COLOR is selected, *READ BLK* is displayed.

READ BLK

2. Measure the black patch. *READ CYN* is displayed.

READ CYN

3. Measure the cyan patch. *READ MAG* is displayed.

READ MAG

4. Measure the magenta patch. *READ YEL* is displayed.

READ YEL

5. Measure the yellow patch. *O.P.* is displayed. Return to the Trap Measurement procedure.

O. P.

Manual Entry

DMAX is manually entered for visual, cyan, magenta, and yellow by measuring the densities of the solid black, cyan, magenta, and yellow inks. Add the visual densities from the black, cyan, magenta, and yellow inks. Enter this sum for the visual DMAX. Repeat this procedure for each color using the appropriate densities—cyan densities for cyan DMAX, etc.

1. Once COLOR is selected, *READ BLK* is displayed.

READ BLK

2. Press COLOR again and the DMAX values are displayed.

3. Press COLOR to select the desired color.

4. Enter the DMAX value by pressing and holding down the ZERO (▼▲) button, then press the FUNCTION (†) or CAL (S) button to adjust the value until the desired value is shown.
5. Press FUNCTION to return to *O.P.*

Selecting Print Contrast Function.....	7-2
Selecting Print Contrast Mode...	7-3
Selecting Color Measurement Method	7-5
Print Contrast Measurement	7-7
Print Contrast Difference Measurement.....	7-9

Print contrast provides you with the ability to monitor the ¾ tone area and is useful when determining the optimum printing density. Print contrast is calculated using the following:

$$\%PC = \frac{D_s - D_t}{D_s} \times 100 \quad \text{where: } D_s = \text{solid density; } D_t = \text{tone density}$$

For print contrast measurement, you need to set some measurement parameters. You need to select:

- the desired measurement *function* (print contrast) (page 7-2);
- the desired print contrast measurement *mode*—*absolute* print contrast, or print contrast *minus paper* (page 7-3); and
- the desired color measurement *method*—*SINGLE* or *AUTO* (page 7-5).

These parameters must be set for all types of print contrast measurement. Once these parameters are set, you can set your instrument to evaluate measurement data two different ways:

- As straight *print contrast measurement* data. Viewing this data requires no additional setup (page 7-7).
or
- As *print contrast difference measurement* data. This data shows you the amount of difference between the measured print contrast and a pre-set reference print contrast. To view data in this format, you need to establish a reference measurement, and set up the instrument for print contrast difference readings (page 7-9).

SELECTING PRINT CONTRAST FUNCTION

1. If this is your first time selecting a measurement function and mode, you should plug your instrument in using its AC adapter. This will prevent the microprocessor from going into “sleep” mode to save battery power. With the instrument plugged in, you’ll be free to take your time learning this procedure.
2. Next, make sure you have the desired response setting selected, and that the instrument is properly calibrated. These procedures are covered in the chapter 2, “Calibration.”
3. To select the measurement method for measuring print contrast, press the **FUNCTION** button repeatedly until *PC* appears in the display.

PC

Now, you can choose to measure *absolute print contrast*, which will read the print contrast *including* the paper; or to measure print contrast *minus paper*. You make this selection by setting print contrast mode.

SELECTING PRINT CONTRAST MODE

1. Press the FUNCTION button and the COLOR button simultaneously, then release. *N cal T Y* appears in the display, where “T” represents Status response you selected (*T*, *G*, *E*, or *N*).

N cal T Y

2. Press FUNCTION to indicate no, you do not want to calibrate. *N mode Y* appears in the display.

N mode Y

3. Press ZERO to indicate yes, you do want to set mode. $\bar{\wedge}$ *RESP T* appears in the display.

$\bar{\wedge}$ RESP T

4. Press FUNCTION to advance to mode selection. *PC-P* or *PC AB* appears in the display.

PC AB

5. Here is where you select *print contrast minus paper* or *absolute density*.

—If you wish to select *print contrast minus paper*, press ZERO until *PC-P* appears in the display. Then, simply press FUNCTION until you exit mode selection. Minus paper mode is already selected; *PC-P* appears in the display briefly, followed by *PAPER*.

—If you wish to select *absolute print contrast*, press ZERO until *PC AB* appears in the display. Then, simply press FUNCTION until you exit mode selection. Absolute mode is already selected; *PC AB* appears in the display briefly, followed by *SOLID*.

Measurement mode is now selected. Absolute print contrast measurement data will appear with a “^PC” after the value; print contrast minus paper data will appear with an underlined “^PC”.

[m 0.13^PC

Indicates absolute print contrast

[m 0.13^PC

Indicates print contrast minus paper

Measuring PAPER for PC-P Mode

When you select *print contrast minus paper* as the measurement mode, you must provide a reading of the paper before taking color measurements. The instrument will take a measurement of the paper and automatically subtract it from subsequent color measurements. This paper value must be updated before every measurement sequence.

Once *print contrast minus paper (PC-P)* mode is selected, *PAPER* appears in the display. Center the instrument target window over a sample of the paper, then lower the instrument head to take a reading and hold.

PAPER

- If the instrument recognizes the measurement as a paper reading, the display becomes ready for the first color reading.
- If the instrument does not recognize the measurement as a paper reading, *PAPER? Z* appears.

PAPER? Z

Keep the instrument pressed down, then press ZERO to indicate that yes, this is the new paper value. Then, the display becomes ready for the first color reading.

[m 0.13^P C

SELECTING COLOR MEASUREMENT METHOD

You can choose from two different measurement methods using the print contrast function:

- *SINGLE* measurement method simply measures and updates the specific color you selected.
- *AUTO* measurement method measures all four colors, then simply updates and displays the most dominant color.

To select color measurement method:

1. Press **FUNCTION** until *PC* or *PC-P* appears in the display. After a moment, either *SOLID* or *PAPER* appears (depending on the type of measurement—absolute or minus paper).
 - For absolute print contrast, press **COLOR** to display a print contrast value for one of the colors—visual (*v*), cyan (*c*), magenta (*m*), or yellow (*y*).

v 100.0 P _C

- For print contrast minus paper, press **COLOR** then **FUNCTION** to display a print contrast value for one of the colors—visual (*v*), cyan (*c*), magenta (*m*), or yellow (*y*).

m 0.15 P _C

2. Press and hold **COLOR**. One of the color measurement methods—*SINGLE* or *AUTO*—appears in the display. If the method you want appears, simply wait a moment and the color values will appear again.

SINGLE

3. If you wish to change the color measurement method, press **COLOR** again, then again to toggle from one method to the next. When the desired method appears, simply wait a moment and the color values will appear again. The color measurement method is set.

Determining which Method is Active

The active color measurement method is indicated at the far left when color measurement information appears in the display:

- When *SINGLE* is active, no characters are shown at the far left.
- When *AUTO* is active, the characters “A” and “u” appear to the far left of the display.

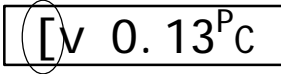

PRINT CONTRAST MEASUREMENT

So far, you have performed the procedures to select print contrast function, mode, and color measurement method.

You are now ready to begin taking measurements to check print contrast values on your press sheet color bar. The type of measurement data that will be displayed will depend on the way you set up your instrument earlier in this chapter. However, for all functions, modes, and methods, the measurement technique is the same.

1. *SOLID* appears in the display.

SOLID

2. Center target window over the solid patch.
3. Lower unit to target window and hold closed. Wait until solid data is displayed. See example below. (If *SOLID? Z* appears in the display or if the solid is displayed as a print contrast value, press *ZERO* to measure the solid before releasing the unit.)

m .450S

4. Once solid data is displayed, release the unit.
5. Once the unit is released, center target window over the 75% tone that corresponds with the previously measured solid.
6. Lower unit to target window and hold closed.
7. Once print contrast data is displayed, release the unit.

m 48.4 ^P C

8. Repeat measuring solids and tones or remaining tones for additional measurements.

Viewing Print Contrast Measurement Data

There are several different combinations of mode and method settings that will affect the way the measurement data is displayed. Since you just set up these parameters yourself, you should see the data in the format you expect. For example, if you set your instrument parameters to *AUTO* and *-PAPER*, your measurement data will appear like this :

[c 1.13^Pc]

“A” and “u” appear to the far left, indicating that the instrument automatically recognized the color—in our example, the color was cyan. And, the “^Pc” after the value is underlined for print contrast minus paper; not underlined for absolute print contrast measurements.

Viewing Measurement Data for Each Color

You can view measurement data in the display for one color at a time. To toggle the display view from one color’s measurement data to the next, press the **COLOR** button when data is displayed. Each time you press, the display switches from visual to cyan to magenta, and so forth.

If you are using the *SINGLE* or *AUTO* measurement method, the data displayed for each color represents the last time that color was measured .

[v 1.13^Pc]

[c 1.17^Pc]

[m 1.18^Pc]

[y 1.02^Pc]

EXAMPLE: Pressing the **COLOR** button repeatedly toggles display from one color’s measurement data to the next.

PRINT CONTRAST DIFFERENCE MEASUREMENT

Print contrast difference measurement uses the same parameters as print contrast measurement. To set up for print contrast difference measurement, follow the procedures earlier in this chapter for selecting print contrast function, mode, and color measurement method.

To view measurement data as a print contrast difference value between a measured sample and a known reference—instead of the print contrast value of the measured sample—you must first enter a reference measurement; and then activate the print contrast difference (*PC-R* or *PC-P-R*) display format.

Entering a Reference Measurement

1. Before measuring your solid, press ZERO twice. *REF* appears for a moment, followed by the current Reference value. If none has been entered, the Reference value is *0.00*.
2. Select the desired ink by pressing COLOR.

<y 16.9R

3. To enter a reference value—or change the current reference value—you can either:
 - measure the reference value directly; or
 - manually enter the reference value using the arrow button functions.

To measure the reference value directly:

Measure the color that you wish to use as the reference. Then, press **FUNCTION** to return to normal operation.

To enter the reference value manually:

Hold down the **ZERO** (▼▲) button, then press the **FUNCTION** (t) or **CAL** (s) button to adjust the value until the desired value is shown. Then, press **FUNCTION** to return to normal operation.

TIP: If you need to move the value up or down by a large amount, hold the arrow button down. The numbers will advance faster as you hold it down.

Activating Print Contrast Difference Display Format

Once you have your reference measurement established and stored in the instrument's memory, you now need to activate the print contrast difference display format:

1. When you press **FUNCTION** and *PC* or *PC-P* appears, press **ZERO** before the display switches to *PAPER* or the first color value. *-R* is added to the function. The display reads either *PC-R* if you are in *absolute* mode; or *PC-P-R* if you are in *minus paper* mode.
2. To de-activate density difference display format, repeat #1 to remove *-R* from the function.

Viewing Print Contrast Difference Measurement Data

There are several different combinations of mode and method settings that will affect the way the measurement data is displayed. Since you just set up these parameters yourself, you should see the data in the format you expect. For example, if you set your instrument parameters to *AUTO*, *-PAPER*, and reference, your measurement data will appear like this:

[C 1.^r13^PC]

“A” and “u” appear to the far left, indicating that the instrument automatically recognized the color—in our example, the color was cyan. The “r” indicates it is a reference measurement. And, the “P” after the value is underlined for print contrast minus paper measurements; not underlined for absolute print contrast.

A “negative” value indicates that the sample was measured to have less print contrast than the reference. If a positive value appears, the sample was measured to have more print contrast than the sample. If 0.00 appears, the sample was measured to have the same print contrast as the reference.

8

Hue Error & Grayness Functions

Formulas	8-1
Selecting Hue Error/Grayness Function.....	8-2
Selecting Hue Error/Grayness Mode	8-3
Hue Error/Grayness Measurement.....	8-5

For hue error and grayness measurements, you need to set some measurement parameters. You need to select:

- the desired measurement *function* (hue error or grayness) (page 8-2); and
- the desired measurement *mode*—*absolute* hue error/grayness, or hue error/grayness *minus paper* (page 8-3).
- **NOTE:** All hue error/grayness function measurements are AUTO only.

FORMULAS

Hue error percentage is calculated as follows:

$$H = \frac{D_M - D_L}{D_H - D_L} \times 100$$

Grayness percentage is calculated as follows:

$$G = \frac{D_L}{D_H} \times 100$$

Where:

- D_H = Highest density of R, G, or B.
- D_M = 2nd highest density of R, G, or B.
- D_L = Lowest density of R, G, or B.

SELECTING HUE ERROR/GRAYNESS FUNCTION

1. If this is your first time selecting a measurement function, you should plug your instrument in using its AC adapter. This will prevent the microprocessor from going into “sleep” mode to save battery power. With the instrument plugged in, you’ll be free to take your time learning this procedure.
2. Next, make sure you have the desired response setting selected, and that the instrument is properly calibrated. These procedures are covered in the chapter 2, “Calibration.”
3. To select the measurement method for measuring hue error and grayness, press the FUNCTION button repeatedly until *H/G* appears in the display.

H/G

Now, you can choose to measure *absolute hue error/grayness*, which will read the hue error/grayness *including* the paper; or to measure hue error/grayness *minus paper*. You make this selection by setting hue error/grayness mode.

SELECTING HUE ERROR/GRAYNESS MODE

1. Press the FUNCTION button and the COLOR button simultaneously, then release. *N cal T Y* appears in the display, where “T” represents Status response you selected (*T*, *G*, *E*, or *N*).

N cal T Y

2. Press FUNCTION to indicate no, you do not want to calibrate. *N mode Y* appears in the display.

N mode Y

3. Press ZERO to indicate yes, you do want to set mode. $\bar{\text{RESP T}}$ appears in the display.

^ RESP T

4. Press FUNCTION to advance to mode selection. *H/G-P* or *H/G AB* appears in the display.

H/G AB

5. Here is where you select *hue error/grayness minus paper* or *absolute hue error/grayness*.

—If you wish to select *hue error/grayness minus paper*, press ZERO until *H/G-P* appears in the display. Then, simply press FUNCTION until you exit mode selection. Minus paper mode is already selected; *H/G-P* appears in the display briefly, followed by *PAPER*.

—If you wish to select *absolute hue error/grayness*, press ZERO until *H/G AB* appears in the display. Then, simply press FUNCTION until you exit mode selection. Absolute mode is already selected; *H/G AB* appears in the display briefly, followed by a color value hue error or grayness.

Measurement mode is now selected. Absolute hue error measurement data will appear with a “H” after the value, grayness with a “G”; minus paper data is indicated by an underlined letter “H” or “G”.

C
m 51.9G

Indicates absolute grayness

C
m 51.9G

Indicates grayness minus paper

Measuring PAPER for Hue Error/Grayness

When measuring hue error grayness minus paper, you must provide a reading of the paper before taking color measurements. The instrument will take the value of the paper and automatically subtract it from subsequent color measurements. This paper value must be updated before every measurement sequence.

Once a *H/G-P* appears in the display. Center the instrument target window over a sample of the paper, then lower the instrument head to take a reading and hold.

PAPER

- If the instrument recognizes the measurement as a paper reading, the display becomes ready for the first color reading.
- If the instrument does not recognize the measurement as a paper reading, *PAPER? Z* appears.

PAPER? Z

Keep the instrument pressed down, then press ZERO to indicate that yes, this is the new paper value. Then, the display becomes ready for the first color reading.

$\frac{C}{m}$ 51.9G

HUE ERROR/GRAYNESS MEASUREMENT

So far, you have performed the procedures to select the correct trap formula and trap function.

You are now ready to begin taking measurements to check trap values on your press sheet color bar. The type of measurement data that will be displayed will depend on the way you set up your instrument earlier in this chapter.

However, for all functions, modes, and methods, the measurement technique is the same. Simply:

1. Center target window over area to be measured.
2. Lower unit to target window and hold closed.
3. Once measurement data is displayed, release the unit.
4. Measurement data will appear either as a normal hue error or grayness value (absolute or minus paper).

Viewing Hue Error/Grayness Measurement Data

Hue error and grayness value color is displayed as color over color at the far left—v (visual), c (cyan), m (magenta), y (yellow)—followed by the hue error or grayness value and mode designation.

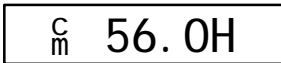

For example, “c” above “m” appearing to the far left, indicates that the color is cyan *towards* magenta. And, the “H” after the value indicates that it is a hue error value; a “G” indicates it is a grayness value—underlined for hue error/grayness minus paper measurements; not underlined for absolute hue error/grayness.

To switch between the hue error value and grayness value, press COLOR.

- Serial Interface Information..... 9-1
- Instrument Specifications..... 9-4
- Accessories 9-6
- General Cleaning..... 9-7
- Optics Maintenance 9-7
- Target Window Replacement.... 9-8
- Lamp Replacement..... 9-9

SERIAL INTERFACE INFORMATION

The connector used for serial input/output is a Modular 10 circuit type. Figure 9-1 is the connection diagram.

Figure 9-1

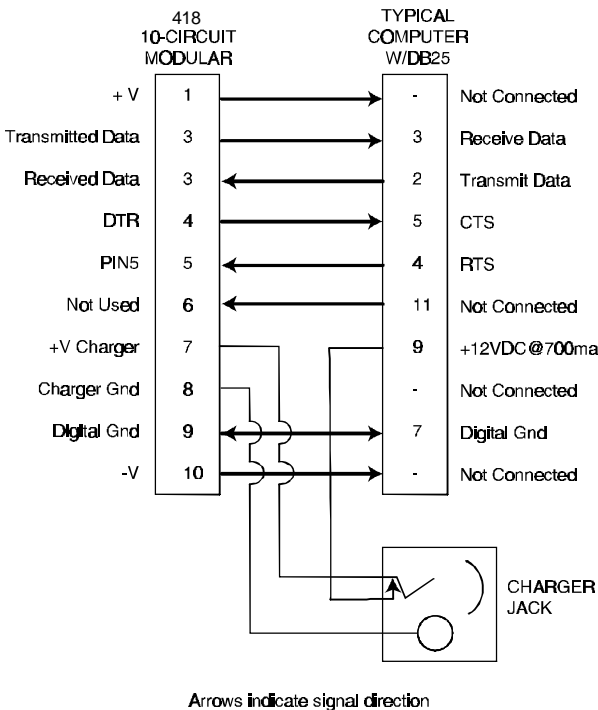

418 Color Reflection Densitometer

An RS232 to modular interface adapter is available from X-Rite which performs as shown in the diagram on the previous page. This adapter also provides a jack for the AC adapter so that only one cable need be connected to the 418. Also, when the adapter is not connected to the jack, the +V CHARGER is connected to pin 9 of the DB25 in the diagram. The charger ground is connected to the jack ground only.

The part numbers for these interface adapters are: P/N 418-70 (male DB25 connector) P/N 418-71 (female DB25 connector) See "Accessories" later in this chapter for other adapters.

A 10-foot modular to modular cable for connection of the 418 to the interface adapter is available by ordering P/N SE108-69.

Term Definitions

Pin 2 Transmitted Data: Data transmitted from the densitometer with parameters (baud rate, format) set by the densitometer.

Pin 3 Received Data: Data received by the densitometer from outside source using the same parameters as the densitometer.

Pin 4 DTR (Data Terminal Ready): Logic 0 active (On Line) and Logic 1 during: Power Off, Power Up, Self Test, during measurements, and when serving RCI.

Pin 5 PIN 5 is set to CTS=logic 0 active; if set to BUSY=logic 1 active; and if set to OFF=ignored.

Pin 7: This pin is used for supplying 12VDC @ 700ma for charging the 418 without having the Adapter connected directly to the unit.

Input Characteristics

Logic 1=+.8VDC to -25VDC

Logic 0=+2.25VDC to +25VDC

Output Characteristics

Logic 1=approximately -4VDC

Logic 0 = approximately +5VDC

Outputs are @ 0VDC during Power Down.

A typical interconnection between the 418 and a computer—in its simplest form—is shown in Figure 9-2.

Figure 9-2

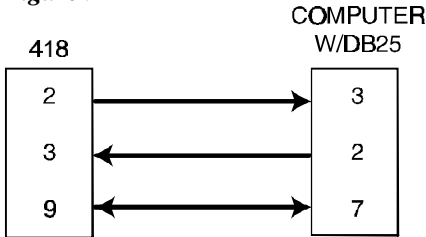

Serial Output

The data format that is transmitted from the 418 is determined by the I/O PORT options found in Chapter 1 under “I/O Port Setup.”

Data transmitted by the 418 shall have one start bit (Logic 0), 7 bits of ASCII, one parity bit (set to Logic 0), and then one stop bit (Logic 1).

Serial Input Commands

Your 418 is equipped with an input that allows the 418 to be controlled or monitored remotely. Every function that can be performed by the 418 (plus a few special functions not activated by the keyboard) can be activated via the serial input. This Remote Control Interface is covered by U.S. Patent 4,591,978.

For more information on Serial Input Commands and remote control operation of the 418, order the Serial Interface Manual, P/N 418-506, from X-Rite, Incorporated.

INSTRUMENT SPECIFICATIONS

Display

Dot Matrix LCD

Measuring Geometry

ANSI PH 2.17/DIN 16536 multi-sensor array

Light Source

Filament bulb 3000°K DIN approx. 2856°K ANSI

Receiver

Silicon Photodiode

Color Response

G optics for X-Rite Graphics Art Response w/ ANSI Status T
Computerized Color Response.

E optics w/47B per DIN16536 w/Glass interference type
Computerized Color Response.

Measuring Range

0.00D-2.5D for G & E

0.00D-2.20D for GS,ES, G/LP, & E/LP

0-100% dot

Reproducibility

$\pm 0.01D$

$\pm 1\%$ for dot area (10-100%)

Linearity

$\pm 0.01D$ or $\pm 1\%$

Inter-Instrument Agreement

$\pm 0.02D$ or $\pm 2\%$

Aperture Diameter

418G,E—3.4mm

418GS,ES—1.7mm

Calibration

Automatic with Quick Cal™

Adjusts Zero and Slope for Density

Computerized Color Response™

Polarization Filter

2 x linear /LP option

Warm Up Time

None

Zero Stability

±.01D maximum per 8 hours

Slope Stability

±1% maximum per year

Power Supply

Six rechargeable AA NiCad batteries 7.2v total rated @600m Ah (included)

Charge Time

Approximately 14 hours

AC Adapter Requirements

418 90-130VAC, 50-60Hz, 18W Maximum
418X 180-260VAC, 50-60Hz, 20W Maximum
12VDC @ 700ma, Positive tip

Operating Temperature Range

50°-104°F /10°-40°C

Measurements Per Charge

Approx. 4500 (usage dependent)

Measuring Time

Approximately 0.6 seconds

Weight

800 grams

Dimensions

7.4cm H x 8.cm W x 19.6cm L

ACCESSORIES

Accessories Included

- Color Reflection Reference
- Operation Manual
- AC Adapter
- Carrying Case

Specifications and design subject to change without notice.

Accessories and Replacement Parts Available

- Polarization Filter.....P/N 418-73
- Security CableP/N 418-75
- 1.7mm Target Window..... P/N 418-21-017-KIT
- 3.4mm Target Window..... P/N 418-21-034-KIT
- 1.7mm ApertureP/N 418-63-017
- 3.4mm ApertureP/N 418-63-034
- Lamp Assembly.....P/N 418-13
- G Optics P/N 418G-35
- G/LP Optics P/N 418G/LP-35
- GS Optics.....P/N 418GS-35
- E Optics P/N 418E-35
- E/LP Optics.....P/N 418E/LP-35
- ES Optics P/N 418ES-35
- Modular Interconnect Cable P/N SE108-69
- DB25P DCE (Null Modem) Interface Adapter.....P/N 418-70
- DB25S DCE (Null Modem) Interface Adapter.....P/N 418-71
- DB25P DTE (Normal) Interface AdapterP/N 418-80
- DB25S DTE (Normal) Interface Adapter.....P/N 418-81
- DB9P Interface AdapterP/N 418-90
- DB9S Interface AdapterP/N 418-91
- Modular Interconnect Cable for Macintosh® computers
with 8 pin mini-DIN connector.....P/N 418-79

For further information on accessories contact your X-Rite representative or call X-Rite, Inc. at: 1-888-826-3059.

GENERAL CLEANING

The exterior of the instrument can be wiped clean with a cloth dampened in water or a mild cleaner whenever required.

NOTE: Do not use any solvents to remove ink from the cover.

OPTICS MAINTENANCE

1. Remove Optics assembly by removing sensor nose screws from densitometer housing, and then lifting the assembly upward. (Figure 9-3)

Figure 9-3

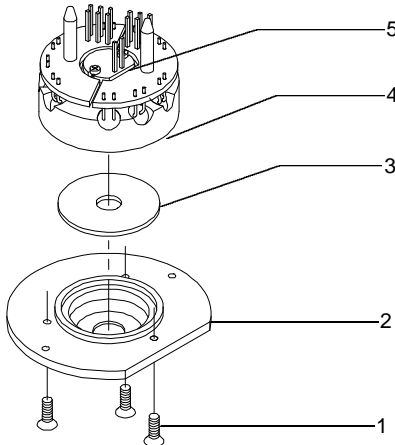

2. Remove three inner screws [1] on sensor nose [2] and rotate Optics over carefully so sensor nose [2] is at bottom.
3. Carefully lift up Optics assembly [4] separating from sensor nose [2].
4. Clean Optics sensors with camelhair brush and set aside.
5. Carefully remove IR Glass [3] and optional polarizing filter (if installed) from sensor nose [2].
6. Remove dust and lint from inner sensor nose and filter(s) with camelhair brush.

418 Color Reflection Densitometer

- Carefully reinstall optional polarizing filter (if used) and IR Glass [3] (holding both by edges) into sensor nose, making sure filter(s) are properly seated.
- Align flat edge of sensor nose [2] with flat edge on Lamp assembly P.C.B [5] and secure sensor nose [2] to Optics assembly [4] with three inner screws [1].
- Carefully reinstall Optics assembly into densitometer by facing flat edge of sensor nose to front of densitometer. Work into position until alignment pins and connector pins are properly seated.
- Insert and tighten sensor nose screws.

TARGET WINDOW REPLACEMENT

- Remove old target window by pushing downward on top of shoe [1]. Clean off any remaining adhesive from shoe. (Figure 9-4)

Figure 9-4

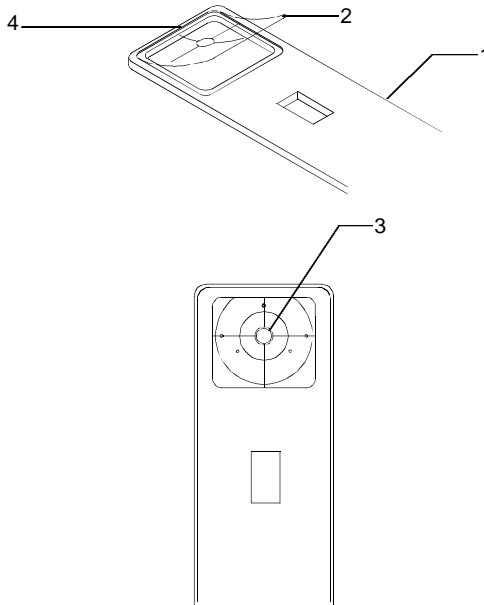

- Turn densitometer over and compress shoe [1] all the way down, and lock shoe.
- Remove paper backing from tape strip on new target window [2].

4. Place one taped edge of target window [2] on indent [4] at bottom of shoe [1].
5. Align hole of target window [2] exactly in center of hole in sensor nose [3] and press remaining three sides of target window into place.
6. Unlock shoe.

LAMP REPLACEMENT

Lamp Removal

1. Remove Optics assembly by removing sensor nose screws [1] from the densitometer housing, and then lifting assembly upward. **THE THREE INNER SCREWS ON SENSOR NOSE ARE NOT TO BE REMOVED.** (Figure 9-5)

Figure 9-5

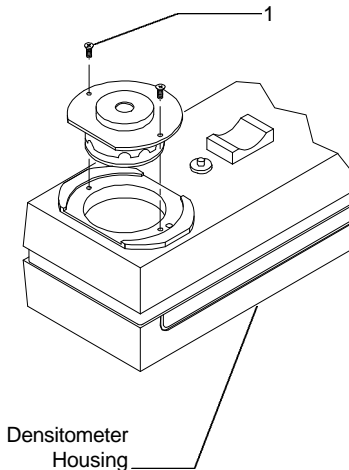

2. Once Optics assembly is free, rotate over and remove two screws [4] from the lamp PCB [3]. (Figure 9-6)

Figure 9-6

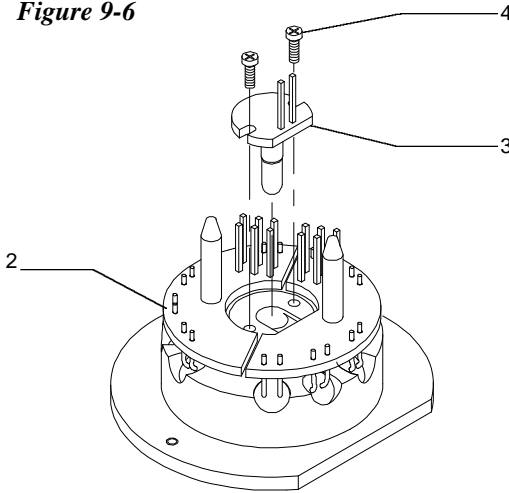

3. Carefully remove old Lamp assembly [3] by lifting upward and discarding.

Lamp Installation

1. Align the flat edges of Optics PCB [2] and new Lamp PCB [3], and insert into Optics assembly. (figure 9-6)

NOTE: EXTREME CAUTION MUST BE TAKEN WHEN INSTALLING NEW LAMP. DO NOT BEND LAMP LEADS.

2. Insert and tighten the two lamp screws [4].
3. Carefully reinstall Optics assembly into densitometer by facing flat edge of sensor nose to front of densitometer. Work into position until alignment pins and connector pins are properly seated.
4. Insert and tighten sensor nose screws [1]. (Figure 9-5)

Display Messages	10-1
Proprietary Notice	10-3
Limited Warranty	10-4
Index	10-5

MISCELLANEOUS DISPLAY MESSAGES

During normal operation, some additional display messages may appear. Following are these messages, what these messages mean and what action must be taken when they appear.

BAT LO indicates that the batteries are getting low and will soon need to be charged. *BAT LO* only appears while the measurement is in progress. Once *BAT LO* is displayed, you will have approximately 100-200 measurements remaining before charging is required.

CHARGE indicates that the batteries are too low to operate the unit and must be recharged. *CHARGE* does not appear until you begin the recharge cycle. Thereafter, the unit will be functional and all previous data will be accessible.

D TOO HI indicates density value measured is too high. Make sure you are measuring the right color for the measurement sequence and try again.

D TOO LO indicates density value measured is too low. Make sure you are measuring the right color for the measurement sequence and try again.

If *D TOO HIGH* or *D TOO LO* continues to appear, re-calibrate the instrument using long calibration (see Chapter 2).

INVALID When the unit is not held down long enough during a measurement, *INVALID* will display.

LAMP FAIL Measurement lamp has failed. The lamp should be examined and replaced. When this message occurs, you can get out

418 Color Reflection Densitometer

of this condition (after replacing lamp) by pressing *FUNCTION* then *COLOR* then *FUNCTION* or waiting until unit powers down.

MEM LOST (Displayed only during power-up) Internal lithium battery is failing. Intermittent connection on Ni-Cad batteries.

NEED CAL Calibration has been lost. The instrument needs calibration.

PAPER Indicates that the next measurement should be paper. If you do not measure paper, “*PAPER? Z*” will be displayed during the measurement.

PAPER? Z (Displayed during measurement) At this point the 418 is asking if this is a new paper value. If it is a new paper value, momentarily press *ZERO* before releasing the read head. If no, release the read head and the display will show normal operation.

SOLID Indicates that a measurement on a solid ink density is necessary. The solid should be measured first, followed by the appropriate tone.

SOLID? Z The 418 is asking if the area measured is a solid. This message appears with a measurement on an overprint, or non-process ink. It also appears when measuring a dot value of 80% or greater, and *ZERO* is pressed. If the area measured is intended to be a solid, momentarily press *ZERO* before releasing the read head. If no, release the read head, numeric data plus *O.P.* (overprint), or dot value is displayed.

PROPRIETARY NOTICE

The information contained in this manual is derived from patent and proprietary data from X-Rite, Incorporated. This manual has been prepared solely for the purpose of assisting operation and maintenance personnel in their use and general maintenance of the X-Rite 418.

The contents of this manual are the property of X-Rite, Incorporated and are copyrighted. Any reproduction in whole or part is strictly prohibited. Publication of this information does not imply any rights to reproduce or use it for any purpose other than installing, operating, or maintaining the equipment described herein.

This instrument is covered by one or more of the following U.S. patents: #4,080,075; #4,591,978; #5,015,098; and patents pending. Foreign patent numbers provided on request.

LIMITED WARRANTY

X-Rite, Incorporated warrants each instrument manufactured by them to be free of defects in material and workmanship for a period of 12 months. THERE ARE NO WARRANTIES OF MERCHANTABILITY OR FITNESS. THIS WARRANTY OBLIGATION IS LIMITED TO SERVICING THE UNIT RETURNED TO THE FACTORY FOR THAT PURPOSE AND EXCLUDES THE LAMP AND NICAD BATTERIES.

The instrument shall be returned with transportation charges prepaid. If the fault has been caused by misuse or abnormal operating conditions, repairs will be billed at a nominal cost. In this case, an estimate will be submitted before work is started, if requested.

A Warranty Registration Card is enclosed with each instrument. The purchaser should fill in the card completely and return it to X-Rite, Incorporated postmarked no later than ten (10) days from the date of receipt. This card registers your system with us for warranty coverage. Once your unit is registered, we are able to maintain a file to help expedite service in case it is needed.

Always include serial number and place of purchase in any correspondence concerning your instrument. The serial number is located at the rear of the instrument.

X-Rite, Incorporated offers a repair program for instruments out of warranty. For more information, contact X-Rite Technical Services Department.

This agreement shall be interpreted in accordance with the laws of the State of Michigan and jurisdiction and venue shall lie with the courts of Michigan as selected by X-Rite, Incorporated.

Index

- A**ccessories, 9-6
- Adjusting the display angle, 1-8
- B**atteries and Power, 1-6, 1-7
- Brunner Trap formula, 6-1
- C**alibration, 2-1, 2-4
 - Color Correlation (CC)
 - Calibration, 2-8
 - Long Calibration, 2-5
 - Quick Cal, 2-11
 - Charging the battery, 1-6
 - Cleaning, 9-7
 - Color measurement method, 4-5
- D**ensity functions, 4-1, 4-2
 - Density difference measurement, 4-8
 - Density measurement. *See*
 - Density mode, 4-3
 - Display messages. *See*
 - Dot functions, 5-1, 5-4
 - Dot area function, 5-6
 - Dot gain function, 5-8
- EFS**[™] (Electronic Function Selection), 3-1
- F**eatures, 1-1
- G**rayness formula, 8-1
- H**ue Error & Grayness Functions, 8-1
- Hue error formula, 8-1
- hue error/grayness functions
 - hue error/grayness measurement, 8-5
 - Hue Error/Grayness mode, 8-3
- I**/O port setup, 1-9
- Instrument Vocabulary drawings, 1-4
- M**aintenance, 9-7, 9-8, 9-9
- Murray-Davies formula, 5-2
- N**ewsprint Trap formula, 6-1
- P**ackaging and Parts, 1-3
- PAPER, 4-4
- Powering the Instrument, 1-6
- Preucil (GATF) formula, 6-1
- Print Contrast Functions, 7-1, 7-2
 - Print Contrast difference measurement, 7-9
 - Print Contrast measurement, 7-7
 - Print Contrast mode, 7-3
- Q**uick Cal[™], 2-11
- R**esponse settings, 2-1
- Responses, 2-2
- Return Packaging, 1-3
- RS232 connector interface, 1-11
- S**electing response, 2-2
- Serial interface information, 9-1
- Specifications, 9-4
- T**rap DMAX entry, 6-10
- Trap Functions, 6-1
 - Trap measurement, 6-5
- U**nlocking/Locking the Shoe, 1-5



X-Rite, Incorporated—World Headquarters

3100 44th Street S.W. • Grandville, Michigan 49418 • USA

www.x-rite.com • (616) 534-7663

Toll-Free U.S. Numbers

Tel: 1-888-826-3059 • Fax: 1-888-826-3061

Toll-Free International Numbers

Tel: 1-888-826-3039 • Fax: 1-888-826-3041

X-Rite GmbH

Stollwerckstraße 32 • 51149 Köln • Germany

Tel: (49) 2203-91450 • Fax: (49) 2203-914519

X-Rite GmbH

Sochorova 705 • CZ-682 • 11 Vyskov • Czech Republic

Tel: (420) 507-328197 • Fax: (420) 507-328138

X-Rite Asia Pacific Ltd.

Room 808-10 • Kornhill Metro Tower • 1 Kornhill Road • Quarry Bay

Hong Kong • Tel: (852) 2-568-6283 • Fax: (852) 2-885-8610

X-Rite Ltd.

The Acumen Centre • First Avenue

Poynton, Cheshire • England

Tel: 44-0-1625-871100 • Fax: 44-0-1625-871444

X-Rite Méditerranée

Parc du Moulin de Massy • 35, rue du Saule Trapu • 91300 Massy • France

Tel: 33-1-69.53.66.20 • Fax: 33-1-69.53.00.52

X-Rite Asia Pacific Limited - Japan Office

Suite 506 AIOS Gotanda • 1-7-11 Higashi-Gotanda

Shinagawa-ku, Tokyo • 141-0022 Japan

Tel: 81-3-5447-1607 • Fax: 81-3-5447-1608