

**Counter Top 700 (CF57U)
Counter Top 750 (CFS57U)**

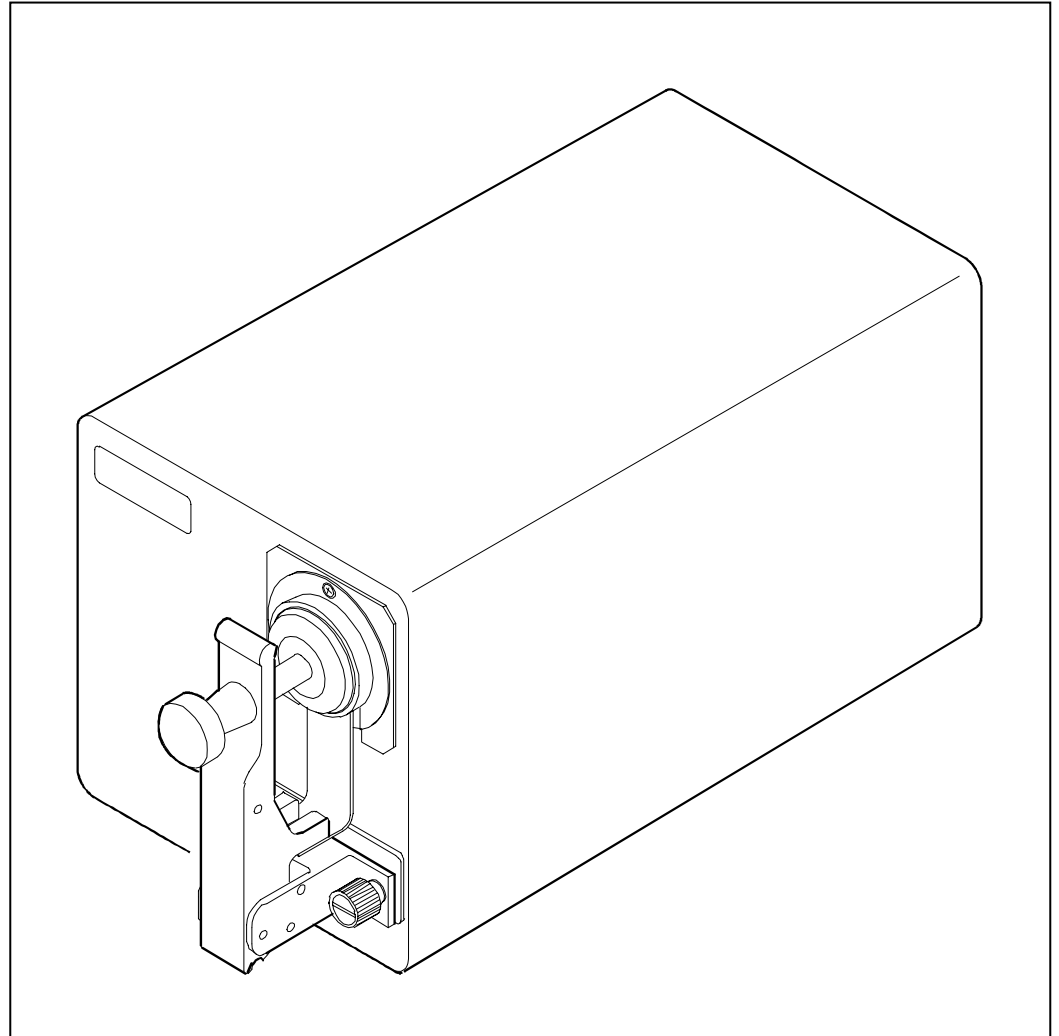

OPERATOR'S MANUAL





Dear Customer:

Congratulations! We at X-Rite, Incorporated are proud to present you with a CF57U/CFS57U color measurement instrument. This instrument represents the very latest in color technologies. As a result, your CF57U/CFS57U is a rugged and reliable instrument whose performance and design exhibit the qualities of a finely engineered instrument, which is not surpassed.

To fully appreciate and protect your investment, we suggest that you take the necessary time to read and fully understand this manual. As always, X-Rite stands behind your unit with a one year limited warranty, and a dedicated service organization. If the need arises, please don't hesitate to call us. The customer service telephone number is 1-800-572-4626.

Thank you for your trust and confidence.

X-Rite, Incorporated

CE DECLARATION

Manufacturer's Name:	X-Rite, Incorporated
Manufacturer's Address:	4300 44 th Street, S.E. Grand Rapids, Michigan 49512 U.S.A.
Model Name:	Spectrophotometer
Model No.:	CF57, CFS57, CF57U, CFS57U
Directive(s) Conformance:	EMC 89/336/EEC LVD 73/23/EEC, 93/68/EEC

WEEE

As of August 13, 2005, X-Rite products meet the European Union – Waste Electrical and Electronic Equipment (WEEE) directive. Please refer to www.xrite.com for more information on X-Rite's compliance with the WEEE directive.



This product may contain PVC (polyvinyl chloride) coated wires, cables and plugs.

Notice

This product may or may not be supplied with a detachable power cord. Use an IEC320/C7 or IEC320/C13 detachable power cord from an approved agency in your region to meet your power requirements.

Hinweis

Dieses Produkt ist mit und ohne abnehmbares Stromkabel erhältlich. Verwenden Sie das abnehmbare Kabel IEC320/C7 oder IEC320/C13 (je nach Stromversorgung), welches Sie bei einem autorisierten Händler erhalten können.

Nota

Este producto se suministra con o sin cable extraíble. Use un cable extraíble de potencia IEC320/C7 o IEC320/C13 de un proveedor autorizado en su región para adecuarse a los requisitos de potencia.

Nota

Questo prodotto viene consegnato con o senza cavo di potenza staccabile. Usare un cavo approvato IEC320/C7 o IEC320/C13 da un'agenzia autorizzata nella vostra regione per essere conforme ai requisiti di potenza.

Observação

Este produto é fornecido com ou sem cabo descartável de potência. Use um cabo aprovado IEC320/C7 ou IEC320/C13 de uma agência autorizada em sua região para atender aos requerimentos para potência.

Avis

Un câble d'alimentation électrique amovible peut être inclus avec ce produit. Utilisez un câble d'alimentation électrique amovible IEC320/C7 ou IEC320/C13 approuvé par une institution reconnue dans votre région pour satisfaire à vos exigences en matière d'alimentation électrique.

通告

本产品可能未提供可拆式电源线。请使用您所在地区的已认证机构所提供的 IEC320/C7 或 IEC320/C13 可拆式电源线，以满足您的电源要求。参见部分认证机构的清单。

使用上の注意

本製品には、取り外し可能な電源コードが付属している場合と付属していない場合があります。ご使用地域の電源をご確認の上、取り外し可能な認定コード IEC320/C7 または IEC320/C13 をお求めください。下記は認定機関の一例です。

User Information

FCC

This equipment has been tested and found to comply with the limits for a Class A digital device, pursuant to Part 15 of the FCC Rules. These limits are designed to provide reasonable protection against harmful interference when the equipment is operated in a commercial environment. This equipment generates, uses, and can radiate radio frequency energy and, if not installed and used in accordance with the instruction manual, may cause harmful interference to radio communications. Operation of this equipment in a residential area is likely to cause harmful interference in which case the user will be required to correct the interference at his own expense.

Canada

This Class A digital apparatus meets all requirements of the Canadian Interference-Causing Equipment Regulations.
Cet appareil numérique de la classe A respecte toutes les exigences du Règlement sur le matériel brouilleur du Canada.

WARNING: To maintain safe operation of this equipment, do not modify ground circuit in any manner. Use of this equipment other than what it was intended for voids all safety assurance.

ADVERTENCIA Para mantener la segura operación de este aparato, **NO** modifique el circuito a tierra. El uso de este aparato para otra cosa que su intención original, anulará todas las garantías de seguridad.

AVVERTIMENTO Per mantenere la sicura operazione di quest'apparecchio, **NON** modificare il circuito a terra. Il uso di quest'apparecchio per altra cosa di suo intenzione originale, annullerà tutte le garanzie di sicurezza.

WARNUNG: Um das Produkt innerhalb von FCC (Vereinigten Staaten) und europäischen Emissionsrichtlinien zu halten, müssen geschirmte Schnittstellenkabel verwendet werden.

AVERTISSEMENT: Pour maintenir la marche sûr de cet équipement, ne modifiez pas de toute façon la circuit de retour par la terre. L'utilisation de cet équipement dans une manière pour ce qu'il n'était pas désigné annulera toutes les assurances de sûreté.

WARNING: This instrument is not for use in explosive environments.

ADVERTENCIA - NO use este aparato en los ambientes explosivos.

AVVERTIMENTO - NON usare questo apparecchio in ambienti esplosivi.

WARNUNG: Das Gerät darf in einer explosiven Umgebung NICHT verwendet werden.

AVERTISSEMENT: Cet instrument ne doit pas être utilisé dans un environnement explosif.

CAUTION: To prevent electrical shock. DO NOT remove cover. No user serviceable parts inside. Refer servicing to qualified service personnel.

ADVERTENCIA Para evitar un choque eléctrico, no quite el recubrimiento del aparato. No hay ninguno componente reparable de usuario, dentro del aparato. Consulte un técnico calificado para servicio o arreglos.

AVVERTIMENTO Per evitare una scossa elettrica, non staccare la coperta del apparecchio. C'è nessuno componenti riparabili d'utente, interno del apparecchio. Consultare un tecnico qualificato per servizio o manutenzione.

VORSICHT: Diese Abdeckung darf nicht entfernt werden, um einen elektrischen Schock zu verhindern. Innen sind keine vom Benutzer zu wartenden Teile. Mit notwendigen Wartungen wenden Sie sich bitte nur an autorisiertes Fachpersonal.

ATTENTION: Pour prévenir un choc électrique, n'enlevez pas cette couverture. Il ne contient aucune pièce réparable. La réparation ne doit être fait que du personnel compétent.

PROPRIETARY NOTICE

The information contained in this manual is derived from patent and proprietary data of X-Rite, Incorporated. This manual has been prepared solely for the purpose of assisting in the use and general maintenance of this instrument.

The contents of this manual are the property of X-Rite, Incorporated and are copyrighted. Any reproduction in whole or part is strictly prohibited. Publication of this information does not imply any rights to reproduce or use this manual for any purpose other than installing, operating, or maintaining this instrument. No part of this manual may be reproduced, transcribed, transmitted, stored in a retrieval system, or translated into any language or computer language, in any form or by any means, electronic, magnetic, mechanical, optical, manual, or otherwise, without the prior written permission of an officer of X-Rite, Incorporated.

This instrument may be covered by one or more patents. Refer to the instrument for actual patent numbers.

Copyright © 2007 by X-Rite Incorporated

“ALL RIGHTS RESERVED”

X-Rite® is a registered trademark of X-Rite, Incorporated
All other logos, product names, and trademarks mentioned are the property of their respective manufacturers.

LIMITED WARRANTY

X-Rite, Incorporated (“X-Rite”) warrants each instrument manufactured to be free of defects in material and workmanship (excluding battery pack) for a period of 12 months. This warranty shall be fulfilled by the repair or replacement, at the option of X-Rite, of any part or parts, free of charge including labor, F.O.B. its factory or authorized service center.

This warranty shall be voided by any repair, alteration, or modification, by persons other than employees of X-Rite, or those expressly authorized by X-Rite to perform repairs, and by any abuse, misuse, or neglect of the product, or by use not in accordance with X-Rite’s published instructions.

X-Rite reserves the right to make changes in design and /or improvements to its products without any obligation to include these changes in any products previously manufactured. Correction of defects by repair or replacement shall constitute fulfillment of all warranty obligations on the part of X-Rite.

THIS WARRANTY IS EXPLICITLY IN LIEU OF ANY OTHER EXPRESSED OR IMPLIED WARRANTIES, INCLUDING ANY IMPLIED WARRANTY OF MERCHANTABILITY OR FITNESS FOR ANY PARTICULAR PURPOSE. THIS WARRANTY OBLIGATION IS LIMITED TO REPAIR OR REPLACEMENT OF THE UNIT RETURNED TO X-RITE OR AN AUTHORIZED SERVICE CENTER FOR THAT PURPOSE.

This agreement shall be interpreted in accordance with the laws of the State of Michigan and jurisdiction and venue shall lie with the courts of Michigan as selected by X-Rite, Incorporated.

TABLE OF CONTENTS

The manual is organized into five sections and two appendices. In order to make the best use of your instrument, it is recommended that you read all sections and appendices.

SECTION ONE - Getting Started

Unpacking and Inspection _____	1-1
Packing Drawing and Parts List _____	1-1
Product Description _____	1-2
Sample Holder _____	1-3
Installing the Sample Holder _____	1-4
Using the Sample Holder _____	1-4
System Connections _____	1-5
Connecting Power _____	1-5
DB9 Cable Interface _____	1-5
USB Cable Interface and Driver Installation _____	1-6
Applying Power _____	1-6

SECTION TWO - Color Reading

Positioning the Color Sample _____	2-1
Measuring Large and Oddly-Shaped Samples _____	2-2

SECTION THREE - Calibration _____ 3-1

SECTION FOUR - General Maintenance

Cleaning _____	4-1
General Cleaning _____	4-1
Cleaning the Sample Port _____	4-2
Cleaning the White Calibration Disk _____	4-3
Replacing the Fuse _____	4-4

SECTION FIVE - Troubleshooting Tips _____ 5-1

APPENDIX A - Technical Specifications _____ A-1

APPENDIX B - Parts and Packaging Drawing _____ B-1

Getting Started

This section covers unpacking, inspection, and installation of your instrument. A general product description and vocabulary illustrations are also included. You should read through this entire section to familiarize yourself with your instrument.

Section One Contents

- Unpacking and Inspection
- General Product Description
- Installing the Sample Holder
- System Connections
- Applying Power

UNPACKING AND INSPECTION

After removing the instrument from the shipping carton, inspect for damage. If any damage has occurred during shipping, immediately contact the transportation company. Do not proceed with installation until the carrier's agent has inspected the damage.

Your instrument is packaged in a specially designed carton to assure against damage. If reshipment is necessary, the instrument should be packaged in the original carton. If the original carton is not available, contact X-Rite, Incorporated to have a replacement shipped to you.

Packaging Drawings and Parts Lists

Check your package contents against your packing list and your original order. Detailed packaging drawing and parts list is included in this manual as *Appendix B*.

PRODUCT DESCRIPTION

The X-Rite CF57U and CFS57U are point-of-purchase paint mix formulation instruments. The instruments are available with either 45°/0° color measurement geometry (CF57U) or spherical geometry (CFS57U).

The instrument provides the means to quickly measure the color of the customer's sample. This color information is then sent from the instrument to the host computer, where the formulation software computes the paint formula to match the customer's sample.

All of these functions are accomplished in a matter of seconds. Each function is displayed on the computer screen where the customer views the entire process.

The instrument reads color samples from a variety of materials including paper, plastic, textiles, and various painted objects. The Sample Holder secures the sample in front of the Sample Port aperture for steady, consistent readings.

The CF57U and CFS57U are self-contained units requiring line power (110/240VAC, 50-60Hz), and serial or USB communication to the host computer. Connections and controls are located on the rear of the unit.

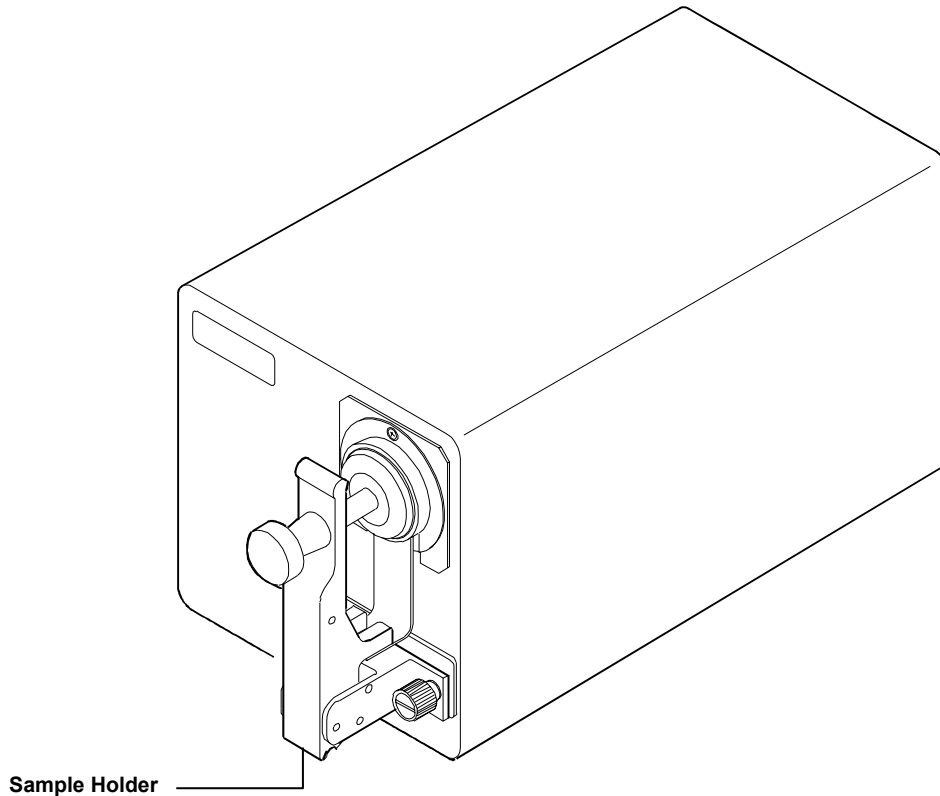

Sample Holder

The Sample Holder is a spring-loaded mechanism that secures a sample in place against the Sample Port for color measurements. Samples are held between the Clamp and Retainer.

For regular measurements, the Cap covers the White Calibration Disk for protection. To calibrate in instrument, the Cap is removed and the sample port simply reads the Calibration Disk.

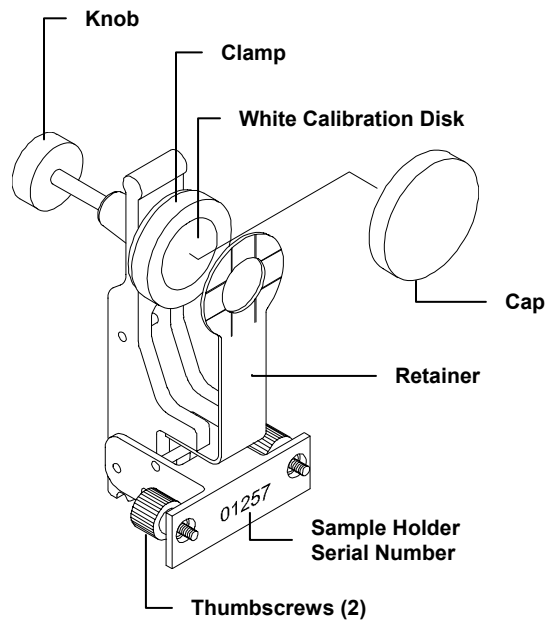

INSTALLING THE SAMPLE HOLDER

The Sample Holder is disconnected from instrument in the packaging. To attach the Sample Holder to the Sample Port:

1. Remove the Adhesive Label from the Sample Port.
2. Remove any residue left by the sticker. Wet a lint-free cloth with alcohol and wipe the area clean.
3. Align the Sample Holder's thumbscrew pins with the pinholes in the Mounting Plate.
4. Tighten each thumbscrew, pressing against the Mounting Plate while turning. Tighten the screws finger tight.

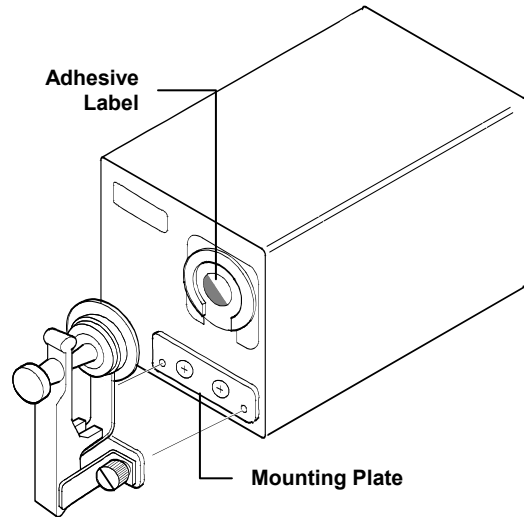

The Cap should rest snugly against the Sample Plane when closed.

Using the Sample Holder

The Sample Holder is spring-loaded in two places for easy sample insertion.

- Pull the top portion of the Holder away from the unit until it locks in nearly horizontal position.
- Pull the Knob back to insert the sample between the Clamp and Retainer.

When sample is in place, carefully guide the knob closed, then guide the Holder back into vertical, closed position.

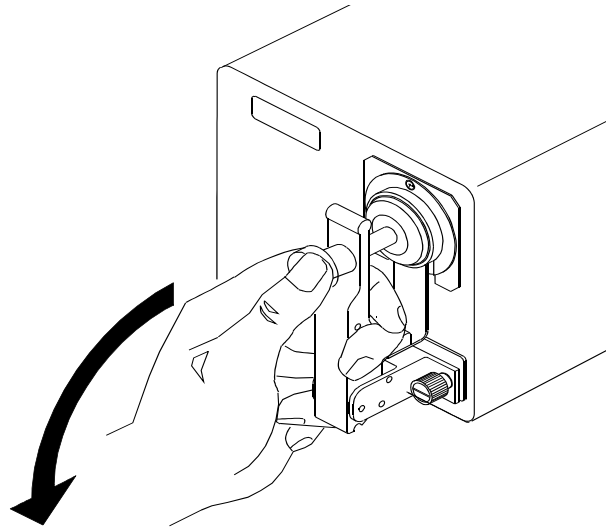

NOTE: When closing the Knob and the Holder, do not allow them to slam shut. This causes premature wear and damage.

SYSTEM CONNECTIONS

Warning: The instrument is not for use in explosive environment.

Connecting Power

- Connect the AC power cord into the Power Input on back of the instrument. Plug the AC power cord into an AC wall outlet.

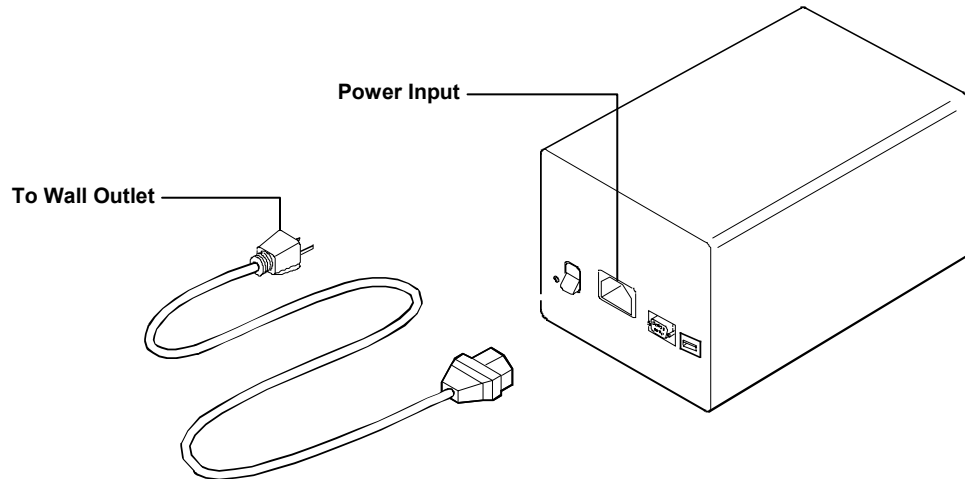

DB9 Serial Cable Interface

NOTE: The instruments can be connected to your computer using a DB9 serial interface cable or a USB interface cable.

1. Attach the male DB9 connector of the cable onto the port on the back of the instrument. Tighten thumbscrews.
2. Attach the female DB9 connector of the cable into an available serial COM port on back of the host computer. Tighten thumbscrews. If required, a DB9-pin to DB25-pin adapter is included in the packaging.

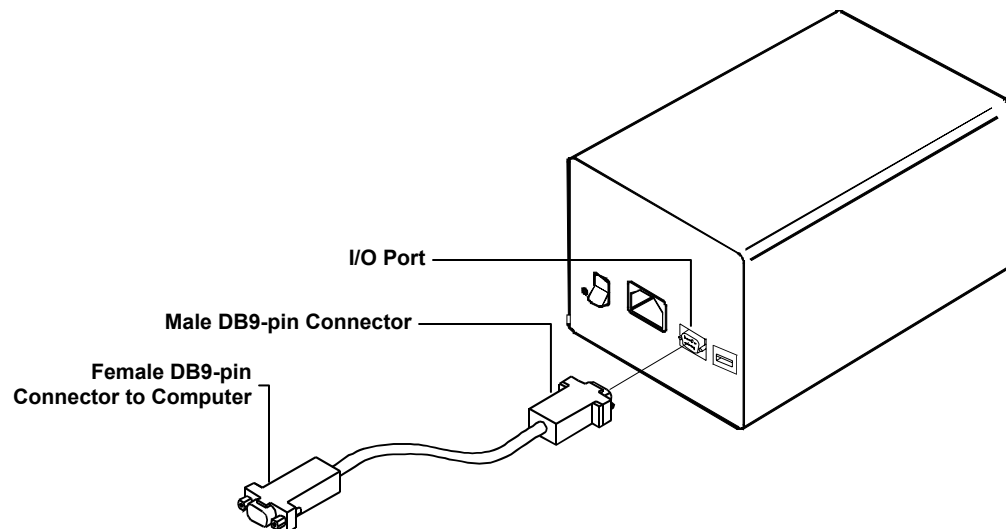

USB Cable Interface

NOTE: The instruments can be connected to your computer using a DB9 serial interface cable or a USB interface cable.

1. Insert the square end of the USB interface cable into the USB port on the back of the instrument.
2. Insert the other end of the USB interface cable into an available USB port on your computer. See Driver Installation below.

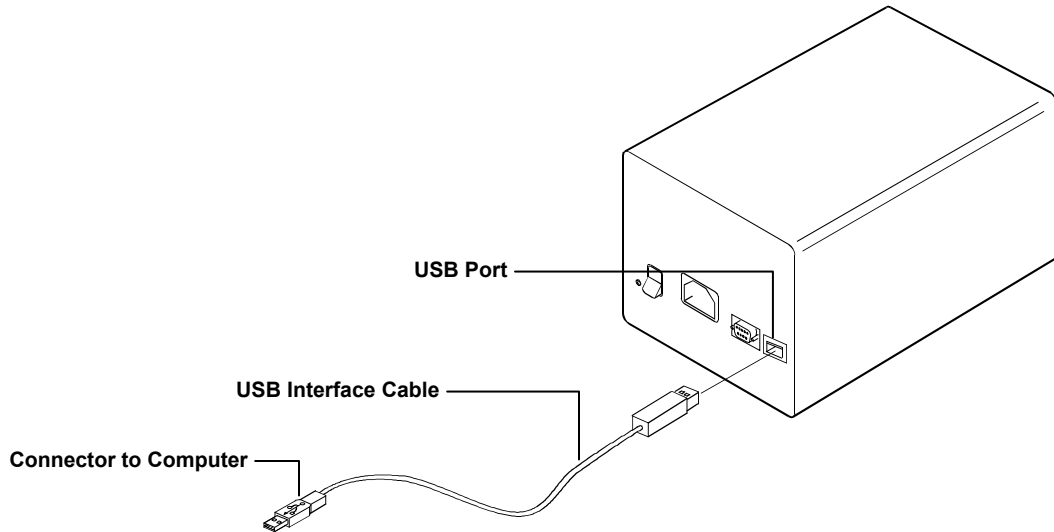

Driver Installation

A USB driver must be installed in the computer to allow the instrument to work with your software application. Follow the steps below to install the required USB driver.

1. Make sure the AC power is on (see next page) and the computer is on.
2. After the USB cable is plugged into your computer, a wizard dialog appears asking for the CF(S)-57 USB driver. Click **Next** to continue.
3. Make sure that the **Search for the best driver for your device** radio button is selected and click **Next** to continue.
4. Check the **Floppy disk drives** box and insert the USB driver disk that was shipped with your instrument into the floppy drive. Click **Next** to continue.
5. Windows begins searching for driver file **AFTDIBUS.INF** on the floppy disk. Click **Next** to install the driver.
6. After the installation is complete, click **Finish**.

7. To use the USB instrument with you software application, you must select the last COM port (such as COM 3) from the list in the application.

APPLYING POWER

Power is applied by flipping the power switch on the back of the instrument in the up position (I). The red lamp next to the switch lights when power is applied.

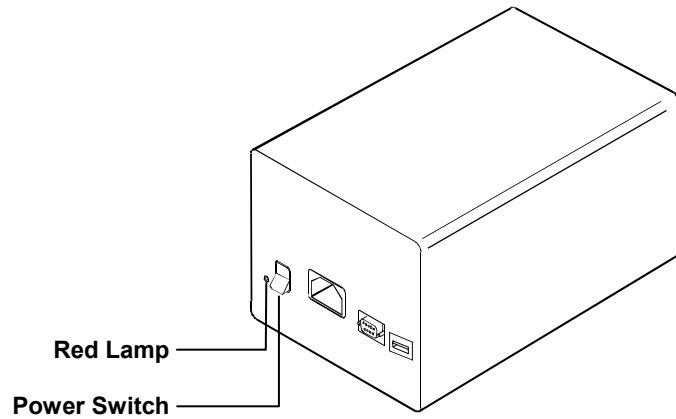

SECTION ONE

Color Reading

This section covers the positioning the sample and measurement techniques.

Section Two Contents

- Positioning the Color Sample

POSITIONING THE COLOR SAMPLE

To measure a sample, the instrument measures the sample through the sample port. To ensure an accurate and reliable measurement, the sample should be held securely against the Port in the Sample Holder.

IMPORTANT Sample Criteria:

- The sample must be at least 1" (25mm) in diameter.
 - The sample color should be uniform and consistent across the measurement area, with no fading or blemishes.
 - The sample should be opaque (solid)—not clear or translucent.
-

To position the color sample:

1. Open the Sample Holder completely.
2. Pull the knob back and insert the color sample between Cap and Retainer. Make sure the sample side you wish to measure is facing the Sample Port.

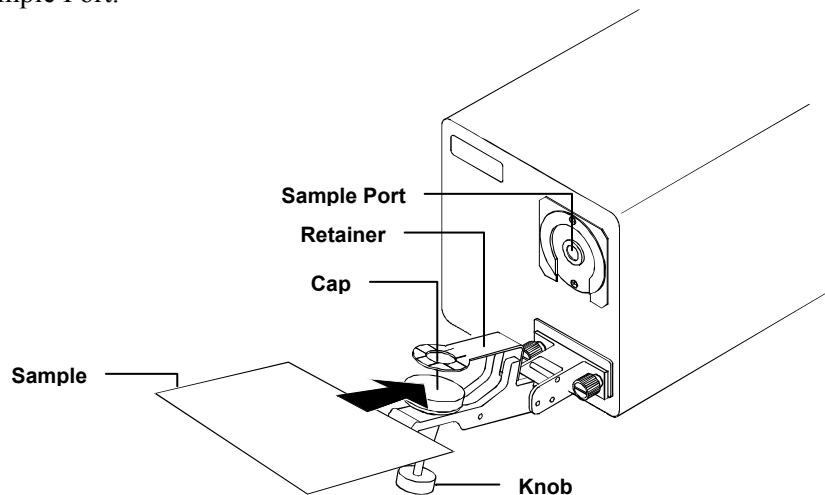

3. Close the Knob against the sample. Make sure the sample covers the entire “eye” opening in the Retainer.
4. Close the Sample Holder. You are now ready to measure the sample.

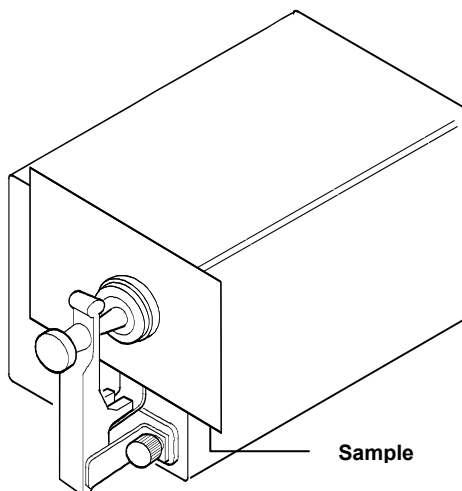

Measuring Large or Oddly-Shaped Samples

Some customers may wish to match a paint color to an object that is too large or oddly-shaped to fit in the Sample Holder conventionally. In these cases, you can either open the Holder completely—or remove the Holder if necessary—then hold the object securely against the Sample Port.

NOTE: Sample Port is Very Sensitive to Movement and Light!

When holding a sample for measurement yourself, remember to keep the sample perfectly still. Also, the sample surface should be able to rest completely flat against the Sample Port, preventing any light from entering the measurement area.

NEVER MEASURE SAMPLES OF WET PAINT

- Wet paint will contaminate the spectrophotometer.
- Wet paint—especially latex—will dry to a significantly different color, resulting in an unsatisfactory match.

Calibration

The instrument is an accurate and reliable precision spectrophotometer used to measure color samples. Regular calibration is important to maintain reliability. The host computer informs the operator when calibration is required.

Measuring the White Calibration Disk that is protected by the Cap performs calibration.

1. Remove the Cap and close the Sample Holder. Follow instructions for calibration on the host computer.
2. Initiate white calibration procedure at host computer.

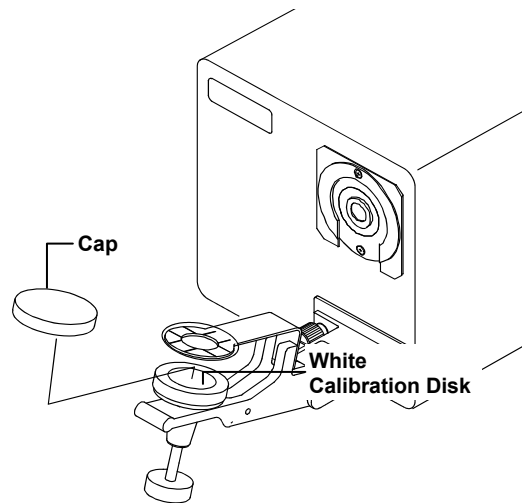

NOTE: The Cap should be removed for calibration *only*. **Do not touch the White Disk—it must be kept clean to ensure accurate measurements.**

The instrument reads the White Disk up to five times (depending on model). The computer screen displays the progress of the reading sequence.

3. After White Disk is measured, open the Sample Holder to allow Open Port readings. Do not put anything in front of the Sample Port during these measurements. Initiate readings at host computer.

The instrument reads the Open Port up to eight times (depending on model). The computer screen displays the progress of the reading sequence.

4. Place the cap back on the White Disk and close the sample holder.
5. Exit calibration procedure at host computer.

SECTION THREE

General Maintenance

This section covers the cleaning and general maintenance of your instrument.

Section Four Contents

- Cleaning
- Replacing the Fuse

CLEANING

Your instrument requires very little maintenance to achieve years of reliable operation. However, to protect your investment and maintain paint formulation accuracy, a few simple cleaning procedures should be performed from time to time.

General Cleaning

The case, Sample Holder and Nose Piece of your instrument should be kept clean and free of dust. This can be accomplished by dusting these components with a lint-free cloth. General cleaning should be performed on a weekly basis, or more often if the unit is used in a dusty operating environment.

Cleaning the Sample Port

The instrument optics should be cleaned periodically depending on specific operating environment and usage.

1. Place the sample holder in the open position.
2. Carefully blow short bursts of clean, dry air into the sample port aperture.

WARNING: *DO NOT* invert cans that use Freon as a propellant. Doing so could cause damage to the optics assembly.

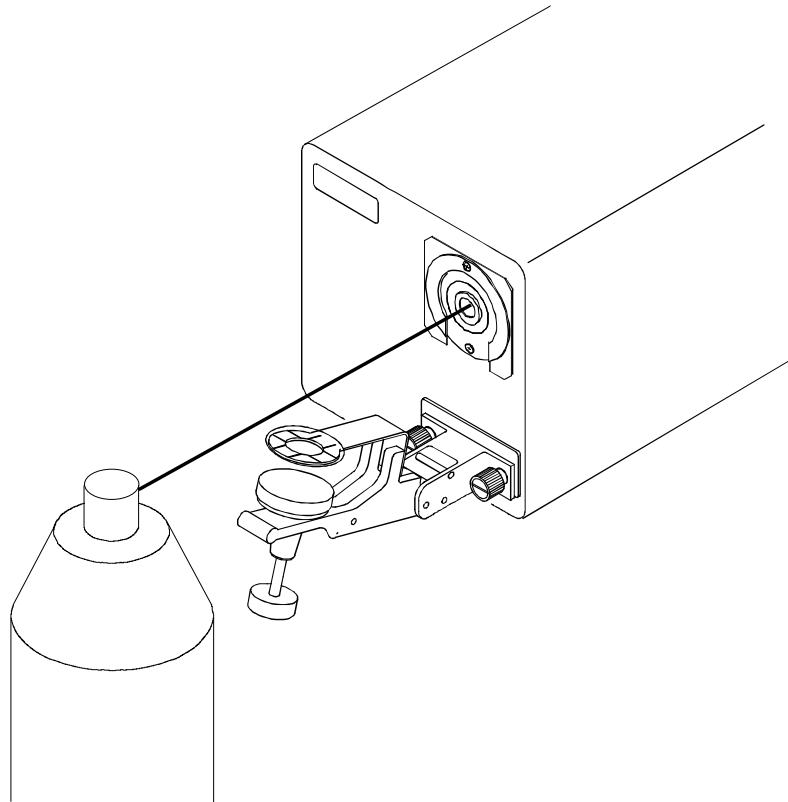

Cleaning the White Calibration Disk

The calibration disk requires very little cleaning because the Cap protects it. When calibrating you should be very careful not to touch the calibration disk. Fingerprints can affect the formulation accuracy of the instrument. Should your calibration disk become dirty or smudged follow the steps below for cleaning.

1. Place the sample holder in the open position.
2. Pull the knob back and remove the cap.

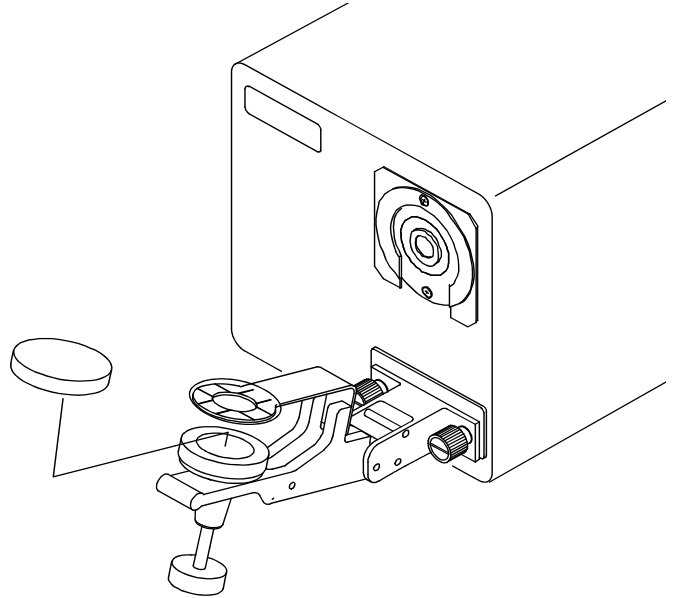

3. Using a lint free cloth, gently rub the white calibration disk until it is free of dust and dirt.

4. Place the cap back on the clamp.
5. Place sample holder in the closed position.

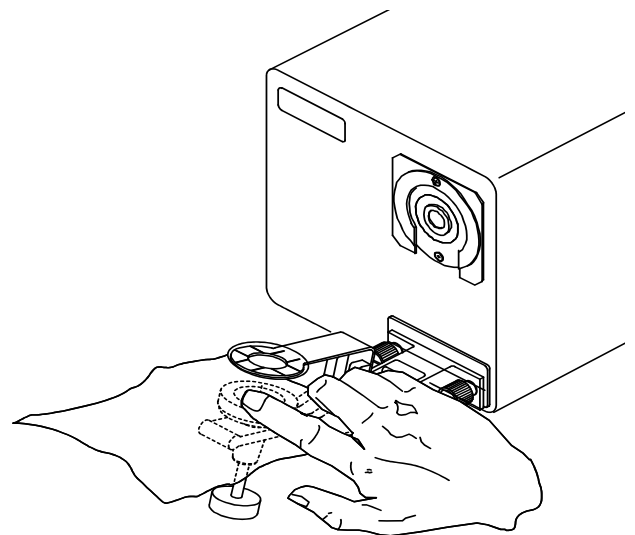

Replacing the Fuse

Part Number SE49-0100 (5mm x 20mm 1A, 250V time-delay fuse).

To replace the fuse:

1. Turn the power off and unplug the detachable line cord.
2. Insert a flat-blade screwdriver into the right edge of the fuse carrier and pry out.
3. Remove the blown fuse from the carrier clip and discard.
4. Place the new fuse in the clip and reinsert fuse carrier into the fuse cavity. Make sure the carrier is firmly seated.
5. Reinstall the detachable line cord.

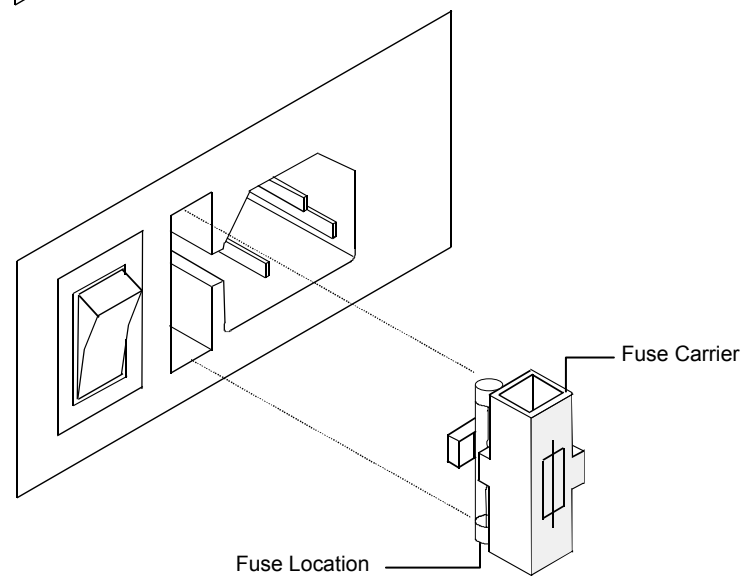
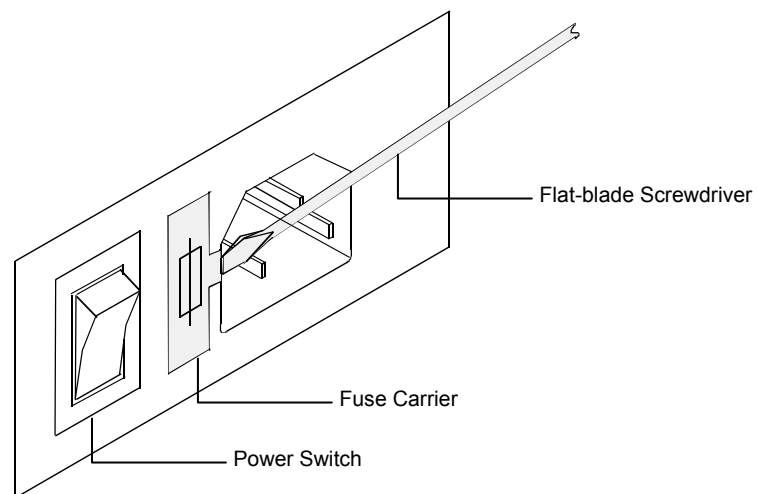

Troubleshooting Tips

The purpose of this section is to help you correct minor problems you may experience while using your instrument. If your instrument does not work after you have checked all the possible solutions, contact X-Rite or your Authorized Service Center. The customer service telephone number is: **1-800-572-4626**.

The following troubleshooting tips consist of a problem that may occur, followed by the step(s) that should be taken to correct the problem.

Instrument does not respond when turned on

- Verify power cable between the instrument and AC (wall) outlet is properly installed (see Section One).
- Verify power switch is on. A red LED light indicates the unit has power.
- Check for a blown fuse (see Section Four).
- Check the COM port or USB port on the host computer.
- If these solutions do not fix the problem, contact X-Rite or an Authorized Service Center.

Sample holder locks closed or hangs up in closed position

- Loosen sample holder thumbscrews and readjust the position, then re-tighten. (The retainer may be interfering with the nosepiece near the port.)
- Contact X-Rite or Authorized Service Center.

SECTION FIVE

Technical Specifications

Dimensions:	5.0 inches (127mm) H x 5.75 (146mm) inches W x 8.625 inches (219mm) L
Weight:	8.13 lbs (3.88kg).
Power Requirements:	100/240 VAC, 50/60Hz, 480VA Nominal $\pm 10\%$ 6 ft. power cord
Measurement Geometry:	CF57U: 45°/0°, fiber optic pickup, dynamic rotational sampling (DRS) CFS57U: Sphere, d/8°, specular component included
Measurement Area:	8.0 mm
Light Source:	Gas filled tungsten lamp, approx. 3000K for CFS57/CFS57U.
Total Lamp Measurement:	45°/0°: 1.0 million, nominal Sphere: 0.5 million, nominal
Spectral Range:	400nm to 700nm
Spectral Interval:	20nm (15nm. bandwidth)
Resolution:	.01%
Warm Up Time:	None
Measurement Time:	4 seconds maximum
Controls:	Power Switch
Operating Temperature:	50 to 104° F (10° to 40°C)
Storage Temperature:	-4 to +122° F (-20° to 50°C)
Humidity:	80% Non-condensing maximum
Altitude:	2000 m
IEC 664:	Pollution Degree 2
Usage:	Indoor only
Installation Type:	Category II

WARNING: Not for use in an explosive environment.

Parts List and Packaging Drawing

Parts List

23	1	1	1	1	SD200-CFS57-06	CARTON INSERT
22	-	-	-	1	SD01-119CH	PRODUCT REGISTRATION CARD, CHINA
	-	-	1	-	SD01-119JA	PRODUCT REGISTRATION CARD, JAPAN
21	1	1	1	1	2102-550	INTERFACE CABLE INFORMATION
20	1	1	1	1	SE108-12-01	SERIAL EXTENSION CABLE
19	2	2	2	2	SD43-82	LABEL - BLANK
18	2	2	2	2	SD65-10	PLASTIC BAG
17	1	1	1	1	SE108-USBAB	USB INTERFACE CABLE
16	-	-	-	-	NOT USED	
15	1	1	1	1	CFS57U-350	USB DRIVER CD
14	1	1	1	1	SD43-CF58-91	SAMPLE HOLDER BOX LABEL
13	-	-	-	-	NOT USED	
12	-	-	-	-	NOT USED	
11	1	1	1	1	SD129-01	DESICCANT
10	1	1	1	1	SD43-48	LABEL
9	-	-	-	1	SD33-41	LINE CORD, CHINA
	-	-	1	-	SD33-31	LINE CORD, JAPAN
	-	1	-	-	SD33-08	LINE CORD 10A, 250v
	1	-	-	-	SD33-07	LINE CORD 10A, 125v
8	1	1	1	1	CF57-500	MANUAL
7	1	1	1	1	SD68-11	ENVELOPE
6	1	1	1	1	SM48-01	PACKAGING MATERIAL, 6" x 10"
5	-	-	-	-	NOT USED	
4	1	1	1	1	SD65-07	BAG
3	1	1	1	1	CF57U-00-01	COLOR FORMULATION INSTRUMENT
2	2	2	2	2	SD200-CFS57-05	CARTON INSERT
1	1	1	1	1	SD200-CFS57-04	CARTON
ITEM	QTY CF57 U	QTY CF57 UX	QTY CF57 UJF	QTY CF57 UCH	PART NUMBER	DESCRIPTION
PARTS LIST						

Packaging Drawing

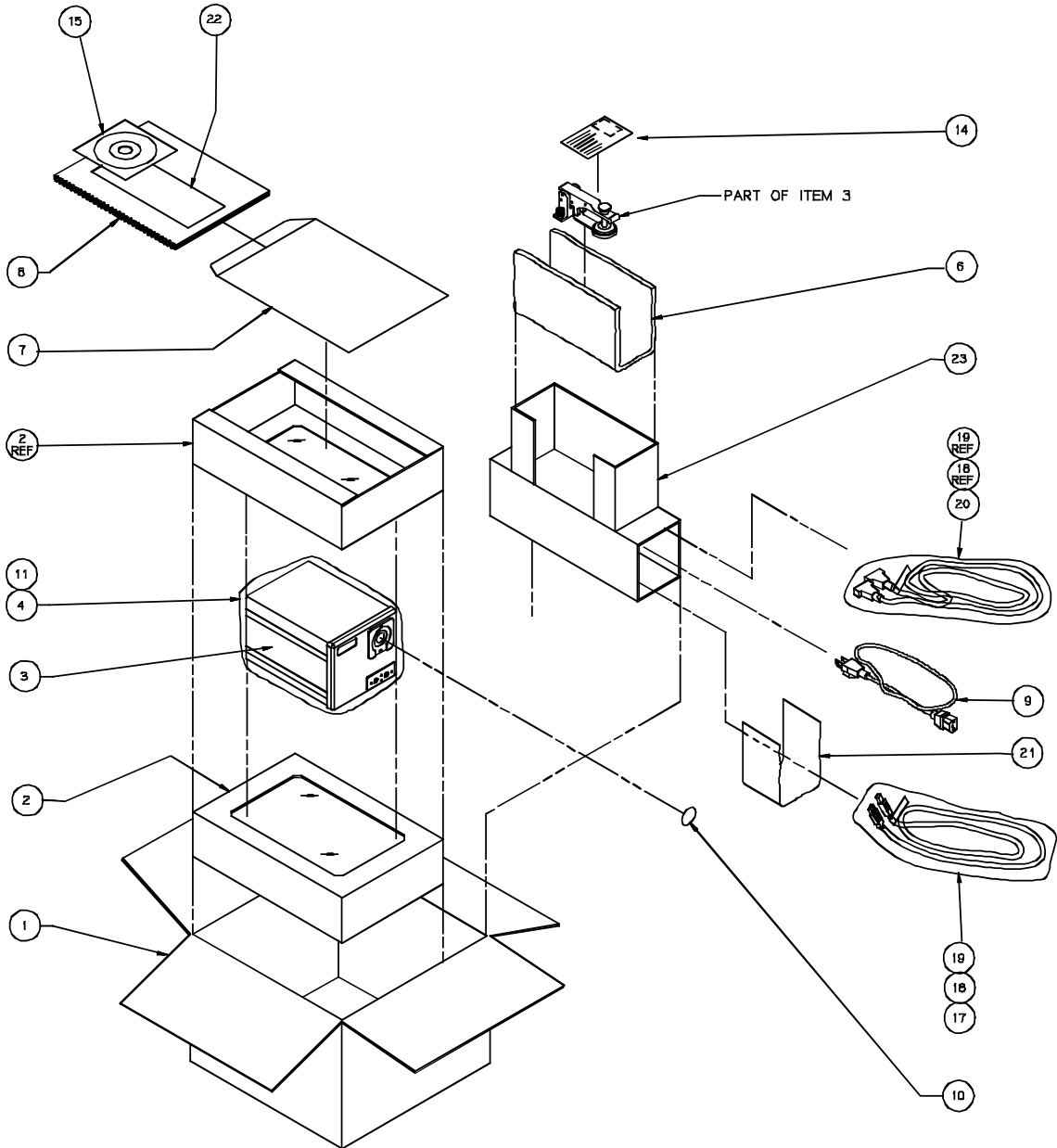



Corporate Headquarters - USA

4300 44th Street SE
Grand Rapids, Michigan 49512
Phone 1 800 248 9748 or 1 616 803 2100
Fax 1 800 292 4437 or 1 616 803 2705

Corporate Headquarters - Europe

Althardstrasse 70
8105 Regensdorf
Switzerland
Phone (+41) 44 842 24 00
Fax (+41) 44 842 22 22

Corporate Headquarters - Asia

Room 808-810
Kornhill Metro Tower, 1 Kornhill Road
Quarry Bay, Hong Kong
Phone (+852) 2 568 6283
Fax (+852) 2 885 8610

Please visit www.xrite.com for a local office near you.